



Solution sets for the Cost reduction of new Nearly Zero-Energy Buildings – CoNZEBS

EU H2020-EE-2016-CSA

Projekt ID: 754046

Solution sets and technologies for NZEBs

Deliverable D5.1

**Kim B. Wittchen & Kirsten Engelund Thomsen
(Danish Building Research Institute, Aalborg University)**

Ove Mørck, Miriam Sanchez Mayoral Gutierrez & Ole Balslev-Olesen (Kuben Management)

Micha Illner, Heike Erhorn-Kluttig & Hans Erhorn (Fraunhofer Institute for Building Physics)

Michele Zinzi & Benedetta Mattoni (ENEA)

**Marjana Šijanec Zavrl, Marko Jačimović & Henrik Gjerkeš
(Building and Civil Engineering Institute ZRMK)**





Disclaimer:

The CoNZEBS project has received funding from the European Union's Horizon 2020 research and innovation programme under grant agreement no. 754046.

The report reflects the author's view. The Commission is not responsible for any use that may be made of the information it contains.

Date: 21/06/19

Version: 2

Title page graphic: Typical multi-family houses used for the CoNZEBS calculations of Denmark, Germany, Italy and Slovenia.

Content

About CoNZEBs.....	5
1. Introduction	7
2. NZEB solution sets	8
2.1. Denmark.....	8
2.2. Germany.....	17
2.3. Italy.....	28
2.4. Slovenia	42
2.5. Solution sets summary.....	48
3. Description of special technologies used in NZEB solution sets	54
3.1. Building envelope.....	55
3.2. Technical building systems	66
3.3. Generation	82
3.4. Heating.....	83
4. Abbreviations / Definitions.....	87
5. Annex I – Solution sets.....	88
5.1. Denmark.....	89
5.2. Germany.....	96
5.3. Italy.....	102
5.5. Slovenia	121

About CoNZEBs

This report is one of the outcomes of the work within CoNZEBs. CoNZEBs is a EU Horizon 2020 project on the topic 'Cost reduction of new Nearly Zero-Energy buildings' (call H2020-EE-2016-CSA, topic EE-13-2016). As such, it receives co-funding by the European Union under the Grant Agreement No. 750046. The project period is from 01/06/17 to 30/11/19.

The planned work can be summarised as follows:

CoNZEBs identifies and assesses technology solution sets that lead to significant cost reductions of new Nearly Zero-Energy Buildings. The focus of the project is on multi-family houses. Close cooperation with housing associations allows for an intensive interaction with stakeholders and tenants. The project starts by setting baseline costs for conventional new buildings, currently available NZEBs and buildings that go beyond the NZEB level based on the experience of the consortium. It analyses planning and construction processes to identify possible cost reductions.

An investigation of end-users' experiences and expectations together with a guide on co-benefits of NZEBs promotes living in these buildings and enhances the energy performance by conducive user behaviour.

The technology solution sets include approaches that can reduce costs for installations or generation systems, pre-fabrication and construction acceleration, local low temperature district heating including RES, and many more. All solution sets are assessed regarding cost savings, energy performance and applicability in multi-family houses. A life cycle assessment of different building levels and NZEBs using the solution sets provides a longer term perspective.

Communication to stakeholders and dissemination of the project results includes events and discussions with the national housing associations.

The CoNZEBS project team consists of 9 organisations from 4 different countries:

Table 0.1: Project partners within the CoNZEBS consortium

Project partner	Country	Website
1 Fraunhofer Institute for Building Physics (Coordinator)	Germany	www.ibp.fraunhofer.de
2 Aalborg Universitet	Denmark	www.sbi.aau.dk
3 Kuben Management AS	Denmark	http://kubenman.dk
4 Agenzia Nazionale per le Nuove Tecnologie, l'Energia e lo Sviluppo Economico Sostenibile (ENEA)	Italy	www.enea.it/en
5 Gradbeni Institut ZRMK doo	Slovenia	www.gi-zrmk.si/en
6 ABG Frankfurt Holding Wohnungsbau- und Beteiligungsgesellschaft mit beschränkter Haftung	Germany	www.abg-fh.com
7 Boligselskabernes Landforening (BL)	Denmark	www.bl.dk/in-english
8 Azienda Casa Emilia Romagna della Provincia di Reggio Emilia (ACER Reggio Emilia)	Italy	www.acer.re.it
9 Stanovanjski Sklad Republike Slovenije, Javni Sklad (SSRS)	Slovenia	http://ssrs.si/

In Germany, national co-funding is provided by Bundesministerium für Umwelt, Naturschutz, Bau und Reaktorsicherheit within the research initiative Zukunft Bau (SWD-10.08.18.7-17.33).

1. Introduction

Solution sets are collections of energy efficient technologies used in nearly zero-energy buildings (NZEB) that in the specific case constitutes a building that meets the national NZEB requirements or beyond. A solution set may vary from one context or location to another and may include any number of technologies. Solution sets have the potential of reducing the cost of currently realised NZEB projects, i.e. a combination of technologies that support/supplement each other in striving towards NZEB at less investment cost. A solution set reduces the overall investment cost for a NZEB. This is achieved either by introduction of less costly solutions in general or by implementing combinations of cost and performance reductions in combination with other cost and performance improvements.

Optimization of costs for variants of NZEBs (i.e. the typical building and all solution sets) originates from information from manufacturers of various technologies. Additionally, the general costs originates from national cost calculation databases:

- 🏠 Denmark: Danish constructions knowledge centre: www.molio.dk.
- 🏠 Germany:
- 🏠 Italy:
- 🏠 Slovenia:

All cost are collected during 2018.

2. NZEB solution sets

This section describes solution sets for nearly zero-energy buildings (NZEBs) in the four participating countries. Furthermore, it contains analyses of solution sets applied to multi-family buildings that are representative for the four countries. Calculations of the energy performance of each solution set has been carried out using national tools. The base case is a typical NZEB solution set in each country to which alternative solution sets are compared concerning the energy performance and the investment costs. The solution sets are defined by the technologies relevant for obtaining the NZEB level.

The calculation for each reference building sets a range for potential cost savings and energy savings (if any).

2.1. Denmark

2.1.1. Typical building

In Denmark, it has been decided to make the initially (2012) announced NZEB building class become a voluntary low energy class. The reasoning for this decision is that the voluntary low energy class is not economical feasible as documented in Danish 2018 EPBD cost-optimal report. This report was published long after starting the work in this project. It was thus decided to continue working on cost optimisation of the voluntary low energy class in contract to moving back to the minimum energy performance requirements as stated in the Danish Building regulations 2018, which has become the official Danish NZEB class. The energy performance requirement for residential buildings in the official Danish NZEB class is 30.5 kWh/(m²yr) (for the typical building) compared to the requirement for the voluntary low energy class of 27 kWh/(m²yr).

The Danish building tradition for multi-family residential buildings is four floors with two flats at each floor in a stairwell and a minimum of three stairwells. The typical flat has a size of 80 m² heated gross floor area¹ (incl. external walls and stairwells). The typical building envelope comprises of brick or prefabricated concrete facade and either flat or pitched roof. Most multi-family residential buildings in Denmark are connected to a district-heating grid for both space heating and domestic hot water and without local production of renewable energy. A Danish NZEB building must have a primary energy demand less than 27 kWh/(m²yr).

¹ NB: All areas in description of the typical Danish building and scenarios refer to the heated gross floor area.

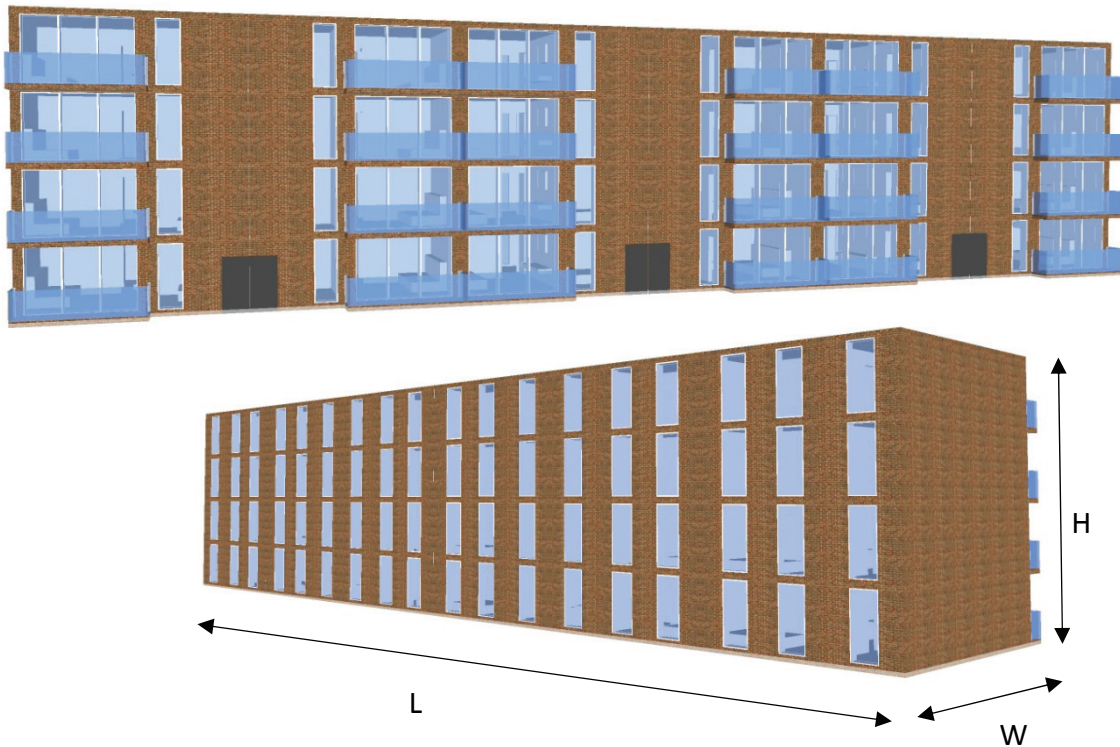

Figure 2.1: Rendering of Danish multi-family building with a total heated gross floor area of 1920 m² (1729.3 m²_{NFA}).

The typical Danish multi-family house is thus a building of four floors with 24 flats each with an average gross floor area of 80 m² (72.05 m²_{NFA}). The external dimensions of the building are L x W x H = 48 x 10 x 12.4 m³, resulting in a heated gross floor area per storey of 480 m² (432.33 m²_{NFA}). The building envelope comprises a prefabricated concrete inner facade leaf with substantial insulation, and an external brick shell. The roof is flat (sloping minimum 4 °) with roofing felt and there is no basement.

Standard conditions for EP calculations

- ⊞ Set point temperature (heating): 20 °C,
- ⊞ Set point temperature (cooling): 23 °C (not used in this context),
- ⊞ Ground temperature: 10 °C,
- ⊞ DHW usage (at 60 °C): 250 l/(m²_{GFA}yr) approx. equal to 14.5 kWh/(m²_{GFA} yr),
- ⊞ Internal load from people: 1.5 W/m²_{GFA},
- ⊞ Internal load from light and appliances: 3.5 W/m²_{GFA},
- ⊞ Energy demand is converted to primary energy using the following factors:
 - ⊞ Electricity: 1.9,
 - ⊞ District heating: 0.85,
 - ⊞ Other: 1.0 (not used in this context).

Envelope characteristics

The envelope is primarily made up of heavy parts, resulting in an average heat capacity of 120 Wh/(m²_{GFA} K).

- ⊞ Window distribution is evenly, with 50 % (211 m²) at each primary facade, i.e. facing North and South respectively. The windows have an average overall U-value of 0.85 W/m²K and the g-value (solar gain factor) is 0.53,
- ⊞ External walls U-value: 0.15 W/(m²K),
- ⊞ Roof U-value: 0.10 W/(m²K),
- ⊞ Slab on ground U-value: 0.10 W/(m²K),
- ⊞ Thermal bridges at foundations: 0.20 W/(mK),
- ⊞ Thermal bridges around windows: 0.03 W/(mK),
- ⊞ Air-tightness meets the BR18² minimum requirements for new buildings, i.e. 1.0 l/(m²s) measured at a pressure difference of 50 Pa.

Technical building systems

- ⊞ Heating, including domestic hot water, comes from district heating. Heating supply in the flats is by radiators in the primary rooms and floor heating at the toilet,
- ⊞ Heat losses from the heat and DHW distribution system inside the building is calculated to 10.0 kWh/(m²K),
- ⊞ Balanced central mechanical ventilation (SEL = 1.2 kJ/m³) with heat recovery (90 %) supply ventilation (0.34 l/(m²_{GFA} s) approx. 0.5 air-change/h).

Energy performance

The calculated primary energy demand is 26.3 kWh/(m²yr), distributed as:

- ⊞ District heating: 23.3 kWh/(m²_{GFA} yr),
 - ⊞ Space heating: 7.2 kWh/(m²_{GFA} yr),
 - ⊞ DHW: 16.1 kWh/(m²_{GFA} yr),
 - ⊞ Electricity (fans and pumps): 3.0 kWh/(m²_{GFA} yr) (excl. household electricity).

The calculated final energy demand is 29.0 kWh/(m²_{GFA} yr), distributed as:

² Danish Building Regulations 2018

- 🏠 District heating: 27.4 kWh/(m²_{GFA} yr),
 - 🏠 Space heating: 8.5 kWh/(m²_{GFA} yr),
 - 🏠 DHW: 18.9 kWh/(m²_{GFA} yr),
 - 🏠 Electricity (fans and pumps): 1.6 kWh/(m²_{GFA} yr) (excl. household electricity).

Costs

- 🏠 Construction costs of building component³: 918 €/m²_{GFA}
- 🏠 Construction costs of technical building systems³: 329 €/m²_{GFA},
- 🏠 Annual design energy costs:
 - 🏠 Electricity for fans and pumps: 0.47 €/(m²_{GFA} yr),
 - 🏠 Electricity for household energy (beyond EPBD calculations): 9.00 €/(m²_{GFA} yr),
 - 🏠 Heating: 2.37 €/(m²_{GFA} yr).

2.1.2. Calculation tool

The ASCOT⁴ tool is a monthly calculation tools based on current the ISO EN 13790 standard for energy calculations. The tool has been developed over the past eight years by Cenergia Energy Consultants. The first version, called BYG-SOL, was initially developed to allow for an easy calculation and comparison of building energy saving technologies and renewable energy in the form of active solar heating systems and photovoltaic systems (PV). From the Danish Building regulation 2006 and onwards the renewable energy contribution is included in the so-called energy frame which is the basis for the Danish building energy requirements and energy certification scheme. The idea of the tool is a simultaneous calculation of energy and costs, so the user can get the energy saving and financial consequences of the investments to save energy and/or harvest solar energy in the form of net present values (NPV), energy saving price and simple payback times. The ASCOT tool has been further developed as part of the work within the IEA Annex 56 to simultaneously produce results for a life cycle assessment (LCA) of the energy renovation technologies selected. The means it automatically delivers results for cost, €/m²yr, GWP, kg CO₂eq/(m²yr) and primary energy, kWh/(m²yr).

³ Average cost of 4 different NZEB Danish building contractors.

⁴ Mørck O. Romeo R. & Zinzi M. On the implementation of an innovative energy/financial optimization tool and its application for technology screening within the EU-project School of the Future. 6th International Building Physics Conference, IBPC 2015.

2.1.3. Solution set optimisation

Typical NZEB

The Danish typical building is, as most Danish multi-family buildings, connected to a district heating grid. There is no requirement for any defined amount of renewable energy in the Danish ZNEB requirements if the building connect to district heating. Due to the widespread deployment of district heating in Denmark, all solution sets base on this technology. Heating delivery is by radiators in the primary rooms and by floor heating in the bathroom. The dominant construction in Danish residential buildings is external bricks with a pre-fabricated concrete inner leaf, which is the construction of the typical building as well. The building envelope in this building must have a dimensioning transmission loss not exceeding 13.7 W/m^2 . Facade windows must have a positive energy balance over the heating season. According to the Danish building Regulations, all multi-family must have balanced mechanical ventilation with heat recovery.

DK-SS1

The first Danish solution set has very efficient insulation material in external walls.

Phenolic insulation boards with a lambda of 0.02 W/mK is used as an alternative wall insulation instead of traditional mineral wool with a lambda value of 0.036 W/mK . This does not change the price of the insulation for the same insulation level. The same heat transfer coefficient can be reached with a smaller insulation thickness, which means larger living area, narrower foundation and frame around windows and doors. Therefore, this alternative insulation does not improve energy performance, but it provides reductions in construction cost of 166 € per flat.

DK-SS2

The second Danish solution set has reduced insulation in walls, roof and floor, and DHW solar heating.

Mineral wool insulation with a lambda value of 0.036 W/mK is used in the building envelope – both in the roof, external walls and floor. Reduced insulation thicknesses is used in this solution set, and other technologies out-balance the reduced energy performance. A smaller insulation thickness means larger living area, narrower foundation and frame around windows and doors. This means considerable reductions in construction cost.

A central solar heating system installed on the roof is a well-known renewable energy technology solution to reduce domestic hot water energy demands. The efficiency parameters are shown in Table 2.1.

Table 2.1: Efficiency parameters for solar heating system.

no	zero loss collector efficiency	0.82
a1	first order heat loss coefficient of solar collector	2.21
a2	second order heat loss coefficient of solar collector	0.0135

Investment costs are 647 €/m² solar panel. Maintenance cost are set as 2 % of the investment cost.

DK-SS3

The third Danish solution set has 4-layer windows, natural ventilation, heat recovery on grey wastewater.

Innovative four layer windows is recently released to the market. It is based on four glazing layers, where the two central layers are half the thickness of usual glass layers in e.g. triple layer windows. They have a thermal conductivity below 0.6 W/m²·K, a solar gain factor of 0.40 and light transmittance of 59 %. This alternative solution achieves heating energy savings of slightly over 30 % compared to the reference triple glazed windows. The total weight of the windows is comparable to the reference windows, but the cost of quadruple glazed windows is approximately 33 % higher compared to triple glazed windows and 44 % higher compared to double-glazed windows.

The natural ventilation solution is a traditional ventilation method by opening windows or using window ventilation flaps. Nowadays, Danish Building Regulation requires the installation of a balance mechanical ventilation system. So, the use of natural ventilation in a multi-family residential building is not allowed. However, in this research project this alternative is analysed in order to compare the performance and cost impact of this solution to mechanical ventilation solutions.

Heat recovery on grey wastewater offers, especially in larger blocks of flats, an opportunity to preheat the freshwater by heat recovery from the grey wastewater, especially wastewater from showers. Theoretically, a recovery efficiency of 50 % is possible.

DK-SS4

The fourth Danish solution set has reduced insulation in walls, roof and floor, decentral mechanical ventilation, energy efficient taps.

Mineral wool insulation with a lambda value of 0.036 W/mK is used in the building envelope – both in the roof, external walls and floor. Reduced insulation thicknesses are used in some of the solution sets, where other technologies out-balance the reduced energy performance. A smaller insulation thickness means larger living area, narrower foundation and frame around windows and doors. This means considerable reductions in construction cost.

Decentralized mechanical ventilation units are an alternative to a traditional central ventilation system installed in a multi-storey building. Decentralized units may have a lower heat recovery efficiency – 85 % and lower electricity consumption – 1.0 KJ/m³, compared to the reference central ventilation system with 90 % heat recovery and 1.2 kJ/m³ energy demand for moving the air (SEL) and higher maintenance and service cost by 5 % compared to reference by 4 %. By contrast, prices are more competitive due to the non-duct installation, easier demand-control, and no need for fire protections.

The energy consumption is very high when opening an ordinary tap for full flow of hot water. However, new water saving mixer taps automatically mix water in an “energy savings mode” with both low temperature and low water flow. The water consumption and therefore the energy consumption of domestic hot water can be reduced by 25 % by new efficient water mixer taps and shower heads (Swedish Energy Agency). Energy saving are 14 kWh/m²_{GFA} equal to 1.3 €/(m²_{GFA}yr). Moreover, these mixer taps reduce the risk of scalding. Investment costs are 1.66 €/m² building heated area. They do not need any maintenance.

DK-SS5

The fifth Danish solution set has reduced insulation in walls, roof and floor, decentral mechanical ventilation, and PV panels.

Mineral wool insulation with a lambda value of 0.036 W/mK is used in the building envelope – both in the roof, external walls and floor. Reduced insulation thicknesses is used in some of the solution sets, where other technologies out-balance the reduced energy performance. A smaller insulation thickness means larger living area, narrower foundation and frame around windows and doors. This means considerable reductions in construction cost.

Decentralized mechanical ventilation units are an alternative to a traditional central ventilation system installed in a multi-storey building.

Decentralized mechanical ventilation units are an alternative to a traditional central ventilation system installed in a multi-storey building. Decentralized units may have a lower heat recovery efficiency – 85 % and lower electricity consumption – 1.0 kJ/m³, compared to the reference central ventilation system with 90 % and 1.2 kJ/m³ energy demand for moving the air (SEL) and higher maintenance and service cost by 5 % compared to reference by 4 %. By contrast, prices are more competitive due to the non-duct installation, easier demand-control, and no need for fire protections.

Mono-crystalline solar cells installed on the roof are also a well-known renewable energy technology solution. Conservative characteristics has been chosen for the analysis: system (wiring, inverters, etc.) efficiency of 80 %, peak power of 180 W/m² and cost of approx. 1548 € per KWp (inclusive VAT). Maintenance cost are set as 1 % of the investment cost.

2.1.4. Solution sets results summary

Table 2.2: Danish solution sets

Solution set results summary		Danish solution sets					
		Typical NZEB (base case)	DK - SS1 More efficient insulation material in external walls	DK-SS2 DHW solar heating, reduced insulation in walls, roof and floor.	DK-SS3 4 layer windows, natural ventilation heat recovery on grey wastewater.	DK-SS4 Reduced insulation in walls, roof and floor, Decentral mechanical ventilation, energy efficient taps.	DK-SS5 PV panels, reduced insulation in walls, roof and floor; Decentral mechanical ventilation.
Building envelope	Average U-value, (incl. windows).	0.26	Id.	0.31	0.21	0.31	0.31
Net energy	Total	17.4	Id.	19.6	19.5	16.9	20.2
Final energy	Total EPBD	29.0	Id.	28.2	30.0	28.5	30.4
	Total (incl. other energy uses)	59.7	Id.	58.9	60.7	59.2	61.1
Primary energy	Total EPBD	26.3	Id.	25.9	25.9	25.9	26.0
	Total (incl. other energy uses)	84.6	Id.	84.2	84.2	84.2	84.3
Energy costs	Total (incl. other energy uses)	11.8	Id.	11.8	11.7	11.7	11.7
	Difference to typical NZEB	-	0.0	-5.5	-18.1	-15.0	-12.6
Investment costs	Difference to typical NZEB	-	-2.1	-5.5	-18.1	-15.0	-12.6

Deviations from the base case (typical NZEB) are marked in bold. Id: Idem - the same as for the base case - The full overview is found in Annex I.

1) Conversion factor: NFA = GFA * 0.9007.

2.2. Germany

2.2.1. Typical building

The German typical multi-family house includes 5 storeys, 15 apartments and in total 1,010.8 m² living area and a net floor area of 984.8 m²_{NFA}. The storey height is 2.78 m and the total building height 15.7 m. Since several types of floor area are used in Germany (and in some of the other countries) the following table allows for the recalculation of all floor area related data used in the German chapters:

Type of floor area	Description	Size [m ²]
Net floor area (NFA)	NFA = Gross floor area minus construction area. NFA is used as main floor area for the area-related energy data in this chapter.	984.8
Living area	The living area is defined in ' <i>Wohnflächenverordnung vom 25. November 2003 (BGBl. I S. 2346)</i> ' and takes into account only the areas that directly belong to an apartment (no common rooms) but instead for example a ratio of balcony areas and a ratio of areas that have a height between 1 and 2 meters.	1,010.8
Useful floor area (A _N)	The useful floor area (Nutzfläche A _N) is an artificial floor area calculated by 0.32 * the gross volume. A _N has to be used for area-related energy data of residential buildings in energy performance certificates. This chapter shows the energy data related to A _N in brackets.	1,240.5
Gross floor area (GFA)	The outside dimensions of the building are used to determine the GFA per storey, which are summed up to the GFA. GFA is not used in Germany for calculating area-related energy data.	1,271.9

There are three different apartment sizes on all storeys with flat #1 having a living area of 54.9 m² (2-room flat), flat #2 of 48.5 m² (2-room flat) and flat #3 of 105.0 m² (4-room flat). A cellar is located beyond the whole building. The (unheated) traffic area is outside on the north side of the building.

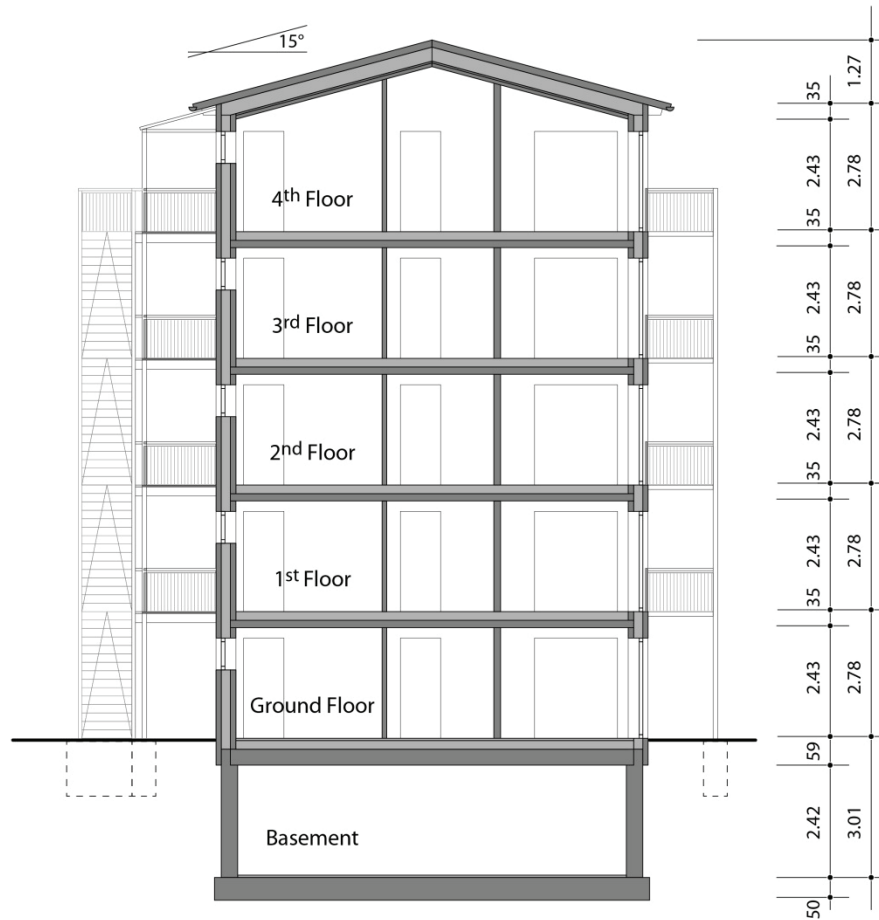

Figure 2.2: Cross section of the Typical German building.

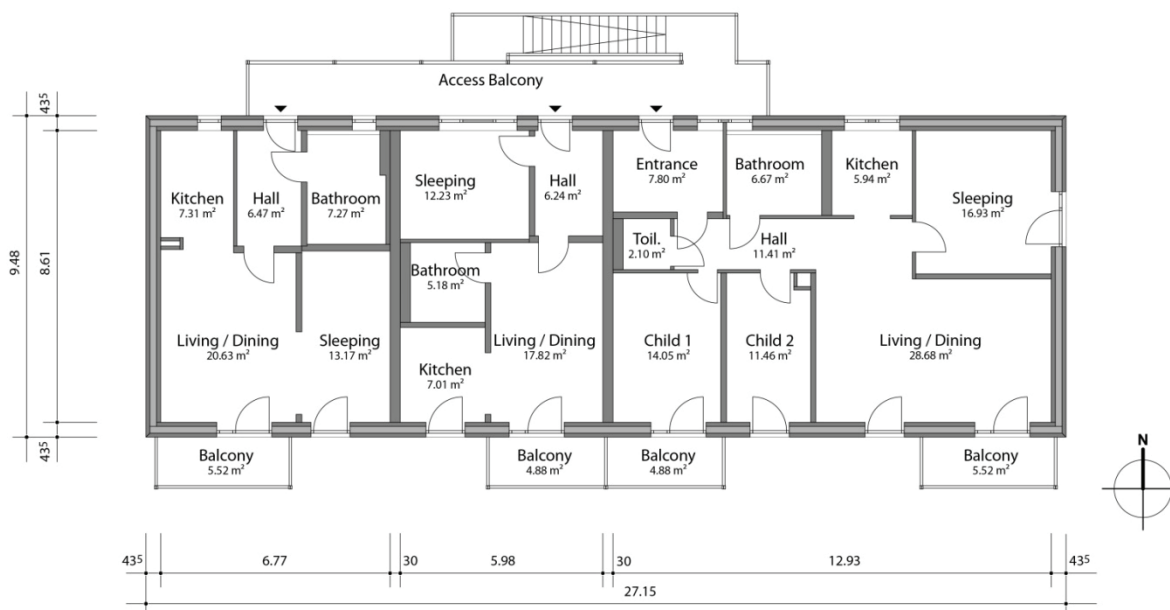

Figure 2.3: Floor plan of the typical German building.



Figure 2.4: South view of the typical German building.

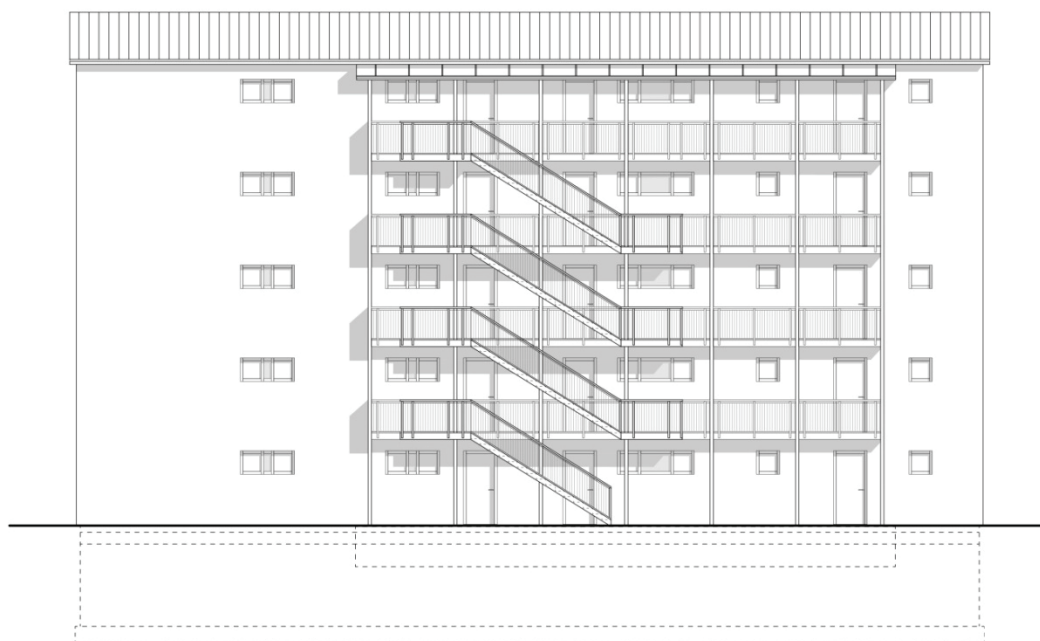

Figure 2.5: North view of the typical German building.

Standard conditions for EP calculations

- 🏠 Set temperature for heating: 20 °C,
- 🏠 Set temperature for cooling: 26 °C (not used in this context),

- 🏠 Basement temperature: 13 °C,
- 🏠 DHW usage: 15 kWh/(m²_{NFA} yr) (national default value),
- 🏠 Internal load from people, light and appliances: 90 Wh/m²_{NFA},
- 🏠 The final energy demand is converted into primary energy using the following factors:
 - 🏠 Natural gas: 1.10,
 - 🏠 Electricity: 1.80,
 - 🏠 District heating (used in one of the solution sets): 0.7
 - 🏠 Solar thermal: 0
 - 🏠 PV electricity (used in one of the solution sets): 0

Envelope characteristics

The choice of building constructions results in a medium heavy building with a heat capacity of 90 Wh/m²_{NFA}.

- 🏠 The total window area is 179.85 m² distributed into 127.45 m² facing South, 34.5 m² North and 17.9 m² East. Windows have an U-value of 0.82 W/m²K with g-value of 0.55 W/m²K,
- 🏠 Wall U-value: 0.10 W/m²K,
- 🏠 Roof U-value: 0.08 W/m²K,
- 🏠 Cellar ceiling U-value: 0.2 W/m²K,
- 🏠 The overall thermal bridge factor of the building is 0.03 W/m²K related to the building envelope area,
- 🏠 The building envelope has an airtightness of 2 air-changes per hour (0.66 l/m²_{NFA} per s) at 50 Pascal pressure difference.

Technical building systems

- 🏠 A condensing gas boiler in combination with a solar thermal collector (47 m²) delivers heat and domestic hot water in the building, and heat distribution is central heating to radiators.
- 🏠 The heat losses inside of the building due to the piping for heating and domestic hot water are specified below.

	Heat losses [kWh/(m ² yr) _{NFA}]	Heat losses [kWh/(m ² yr) _{AN}]
Heating distribution piping	6.54	5.19
Domestic hot water piping to the DHW-storage	1.86	1.48
DHW circulation piping	9.85	7.82

- 🏠 The ventilation system is mechanical exhaust ventilation (efficiency 0.20 W/(m³h) or 0.72 kJ/m³_{air}) with a total ventilation rate of 0.45 air-changes per hour.

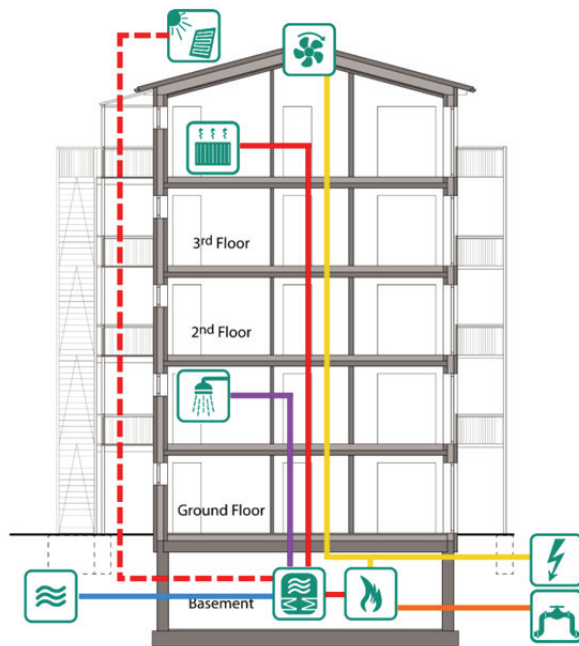

Figure 2.6: Energy concept of the typical German NZEB.

Energy performance

- 🏠 The final energy demand of the building is calculated to be $27.50 \text{ kWh/m}^2_{\text{NFA}}$ ($21.83 \text{ kWh}/(\text{m}^2\text{yr})_{\text{AN}}^5$) for heating (including auxiliaries), $17.17 \text{ kWh}/(\text{m}^2\text{yr})_{\text{NFA}}$ ($13.63 \text{ kWh}/(\text{m}^2\text{yr})_{\text{AN}}$) for domestic hot water (including auxiliaries) and $1.93 \text{ kWh}/(\text{m}^2\text{yr})_{\text{NFA}}$ ($1.53 \text{ kWh}/(\text{m}^2\text{yr})_{\text{AN}}$) for ventilation. The final energy for household electricity was estimated to be $25 \text{ kWh}/(\text{m}^2\text{yr})_{\text{NFA}}$ ($18.85 \text{ kWh}/(\text{m}^2\text{yr})_{\text{AN}}$).
- 🏠 The building has a calculated primary energy demand of $48.86 \text{ kWh}/(\text{m}^2\text{yr})_{\text{NFA}}$ ($38.79 \text{ kWh}/(\text{m}^2\text{yr})_{\text{AN}}$). This is just below the national NZEB requirement of $49.09 \text{ kWh}/(\text{m}^2\text{yr})_{\text{NFA}}$ ($38.97 \text{ kWh}/(\text{m}^2\text{yr})_{\text{AN}}$). Due to missing detailed German application of the NZEB definition, the German CoNZEBS team defined the national NZEB requirement for the project to be the KfW Efficiency House 55, which translates to be about 27 % more tight than the legal minimum energy performance requirement for new buildings.

⁵ A_N ('Gebäudenutzfläche') is a type of artificial floor area used in Germany for relating the calculated energy use of residential buildings. It is calculated by $0.32 \cdot \text{gross volume}$.

Costs

- 🏠 Average construction costs of the building components and the technical building systems for NZEBs have been identified in CoNZEBs D2.1 'Overview of Cost Baselines for three Building Levels' to be 1,974 €/m²_{NFA} or 1,923 €/m²_{living area}.
- 🏠 Annual design energy costs:
 - 🏠 Electricity for fans and pumps: 0.98 €/((m²yr)_{NFA}) (0.77 €/((m²yr)_{AN})),
 - 🏠 Electricity for household energy (beyond EPBD calculation): 7.36 €/((m²yr)_{NFA}) (5.84 €/((m²yr)_{AN})),
 - 🏠 Heating: 2.35 €/((m²yr)_{NFA}) (1.86 €/((m²yr)_{AN})).

2.2.2. Calculation tools

Since 2006, the Fraunhofer Institute for Building Physics (IBP) has been developing the calculation kernel (ibp18599 kernel) to DIN V 18599. DIN V 18599 is one of the mandatorily prescribed calculation methods to issue energy performance certificates for residential buildings and the mandatorily prescribed method for non-residential buildings in Germany. The ibp18599 kernel is continuously maintained, further developed and adapted to the new editions of DIN V 18599. Due to the architecture of the core it is possible to perform calculations according to the various editions of DIN V 18599 (2007-02, 2011-12, 2016-10) and the German Energy Saving Ordinance (EnEV 2007, EnEV 2009, EnEV 2014/2016).

The calculation program IBP:18599 is developed by Fraunhofer IBP and available at <https://ibp-18599.de/>. The program uses the calculation kernel ibp18599kernel. Both the calculation core and the surface IBP:18599 are certified according to the quality association DIN V 18599.

2.2.3. Solution set optimisation

The German CoNZEBs team has identified eight different promising alternative solution sets of which four (DE-SS2, DE-SS3, DE-SS7 and DE-SS8) have resulted in lower investment costs compared to the typical NZEB solution. In order to understand the energy concepts of the typical NZEB and the four solution sets are summarised in the following. More detailed information is included in the appendix.

Typical NZEB

The German base case uses a condensing gas boiler with an atmospheric burner to generate heat for heating and domestic hot water purposes. The heat generation is completed by a 47 m² flat-plate solar collector system, which contributes 11,189 kWh of net energy to the DHW and 2,742 kWh to the heating system.

The heat is distributed through distribution pipes, which are insulated according to the national standard and then emitted via radiators located at external walls. The DHW distribution is also realised via distribution pipes insulated to national standard and a circulation is applied 24/7 using a pressure-controlled demand-driven pump.

For ventilation a demand-controlled mechanical exhaust ventilation system is applied which provides an air change rate of 0.45 1/h.

To fulfil the (CoNZEBs) NZEB requirements with the described technical building services systems the building envelope needs to have a specific transmission heat loss H_T (basically an average u-value of the thermal envelope including temperature correction factors and thermal bridges) of 0.22 W/m²K.

DE-SS2

The first presented German solution set uses decentral electric heating systems in each heated room, like for example heated glass or marble plates. Therefore, no hydronic heat distribution is necessary. The domestic hot water generation is realised by decentral electrical continuous-flow water heaters. To reduce the DHW energy need a part of the fresh water is decentralised pre-heated with the wastewater of the showers before it enters the water heater, thus working as a heat recovery.

The ventilation of the building is realised decentral via reversing airflow ventilation units with heat recovery, which provide an air change rate of 0.45 1/h.

To partially compensate the electricity need a 130 m² (17.6 kWp) monocrystalline, south-oriented PV-system is applied which has a total energy production of 15,948 kWh/yr.

To fulfil the (CoNZEBs) NZEB requirements with the described technical building services systems the building envelope needs to have a specific transmission heat loss H_T of 0.31 W/m²K.

DE-SS3

As SS3, the second presented German solution set is designed without a hydronic heating system. The building has a combined air heating and ventilation system and uses an air-air-heat pump, which extracts the heat from the exhaust air of the central supply and exhaust ventilation system and transfers it to the supply air. An electronic supplementary heater can be used to provide the set supply air temperature. The ventilation rate is 0.45 1/h (0.24 l/m²s)

The domestic hot water generation is realised by decentral electrical continuous-flow water heaters. To reduce the energy need for DHW the fresh water is decentralised pre-heated with the wastewater of the showers before it enters the water heater, thus applying a heat recovery.

To fulfil the (CoNZEBS) NZEB requirements with the described technical building services systems the building envelope needs to have a specific transmission heat loss H_T of 0.31 W/m²K.

DE-SS7

The third presented German solution set features a connection to the district heating network, which generates the heating and DHW needs. Both, heating and DHW, are distributed by pipes insulated according to the national standard. The DHW has a circulation applied 24/7 using a pressure-controlled demand-driven pump.

The ventilation is covered by a demand-controlled mechanical exhaust ventilation system (same technology as in the base case).

To fulfil the (CoNZEBS) NZEB requirements with the described technical building services systems the building envelope needs to have a specific transmission heat loss H_T of 0.31 W/m²K.

DE-SS8

The fourth presented German solution set is a slightly adapted version of the realised energy concept “Frankfurter Klimaschutzhaus” of ABG Holding Frankfurt⁶. The main differences are

⁶ Frankfurter Klimaschutzhaus: Further information can be found at <https://www.conzebs.eu/index.php/nzeb-solution-sets> and <https://www.abg-fh.com/presse/?Im-Wiener-Musterwohnung-in-Oberrad-fertiggestellt&document=4431>

the location of the condensing gas boiler in the cellar and the thermal quality of the building envelope, which is adapted to the (CoNZEBS) NZEB requirements taking into account the different geometry of the German CoNZEBS base building. The solution set contains an exhaust air-water heat pump and a condensing gas boiler, which generate the necessary heating energy at a temperature of 55 °C. The heat is then distributed via pipes (insulated according to national standard) and emitted via radiators located at external walls.

The DHW need is covered by the exhaust air-water heat pump and then distributed to the fresh water stations from where it is delivered to the fixtures and showers.

The ventilation is realised by a mechanical exhaust ventilation system with heat recovery via the exhaust air-water heat pump (air change rate: 0.45 1/h (0.24 l/m²s)).

To fulfil the (CoNZEBS) NZEB requirements with the described technical building services systems the building envelope needs to have a specific transmission heat loss H`T of 0.31 W/m²K.

The four alternative solution sets are summarised in the following schemes:

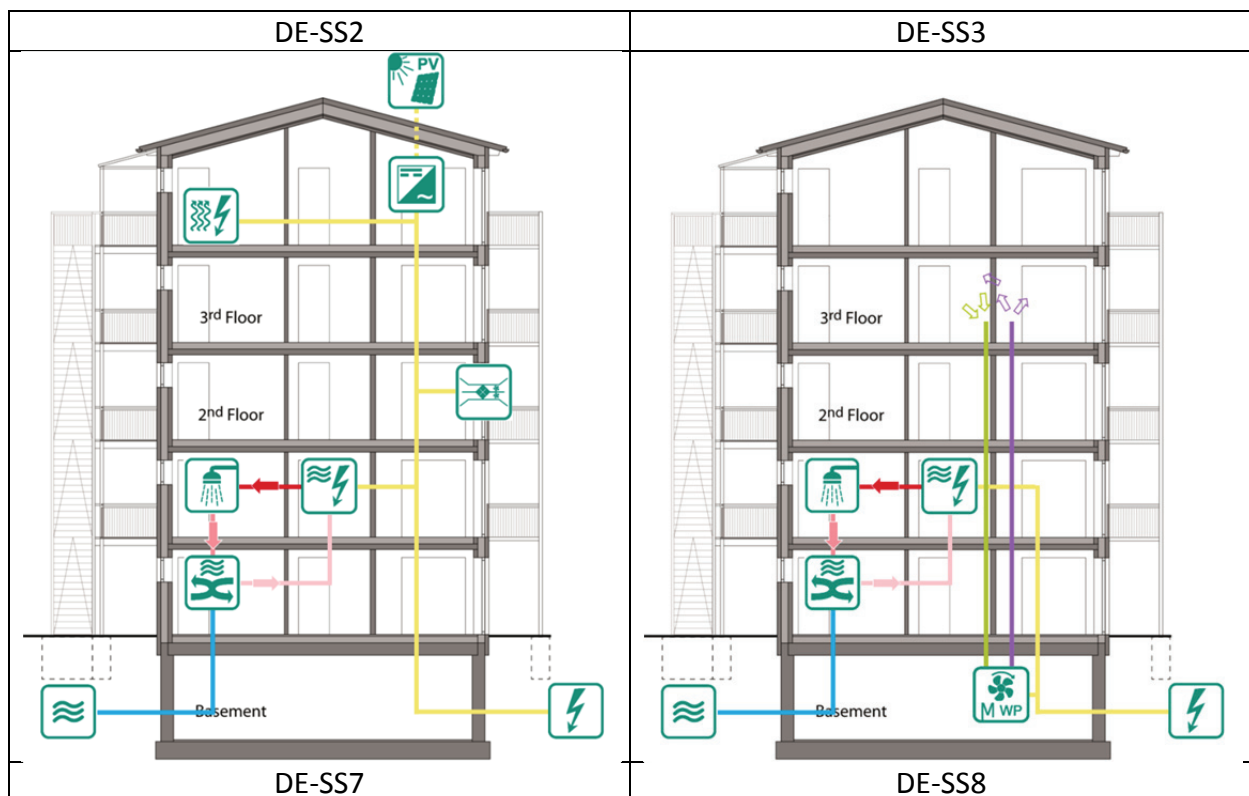

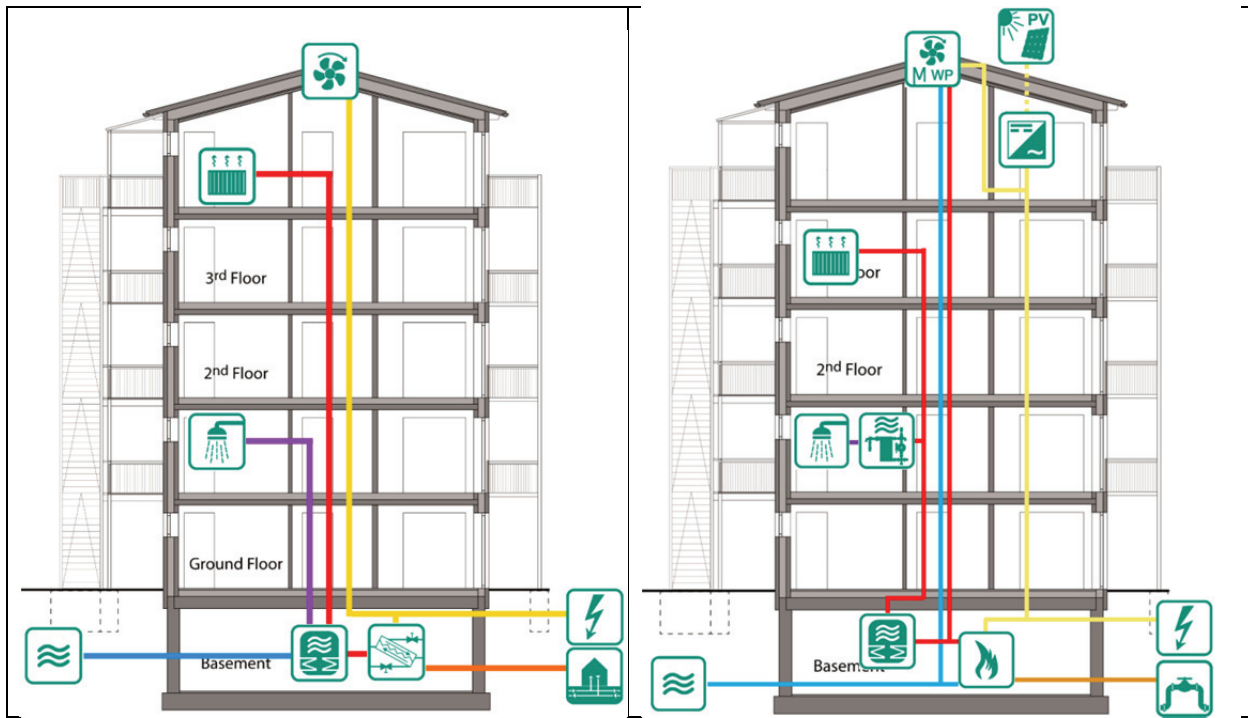

Figure 2.7: Energy concepts of the German solution sets.

2.2.4. Solution sets results summary

Table 2.3: German solution sets.

		German solution sets				
		Typical NZEB (base case)	GER – SS2	GER-SS3	GER-SS7	GER-SS8
Solution set results summary						
All specific values relate to the net floor area of the building.						
Building envelope	Mean U-value (incl. windows) National comparison value: $H'_{T, Ref.} = 0.45 \text{ W/m}^2\text{K}$ $H'_{T, KW, SS} = 0.31 \text{ W/m}^2\text{K}$	0.22	0.31	0.31	0.31	0.31
Net energy	W/m ² K					
Final energy	Total	35.50	35.42	36.24	41.16	49.39
	Total EPBD	46.60	22.83	27.00	65.48	38.27
Primary energy	Total (incl. other energy uses)	71.60	47.83	52.00	90.48	63.27
	Total EPBD	48.85	41.09	48.60	48.39	47.60
Energy costs	Total (incl. other energy uses)	93.85	86.09	93.60	93.39	92.60
	Total EPBD	3.33	6.43	6.91	7.00	4.22
Investment costs	Total (incl. other energy uses)	10.69	14.08	14.27	14.91	11.58
	Difference to typical NZEB	-	-84	-57	-83	-44

2.3. Italy

2.3.1. Typical building

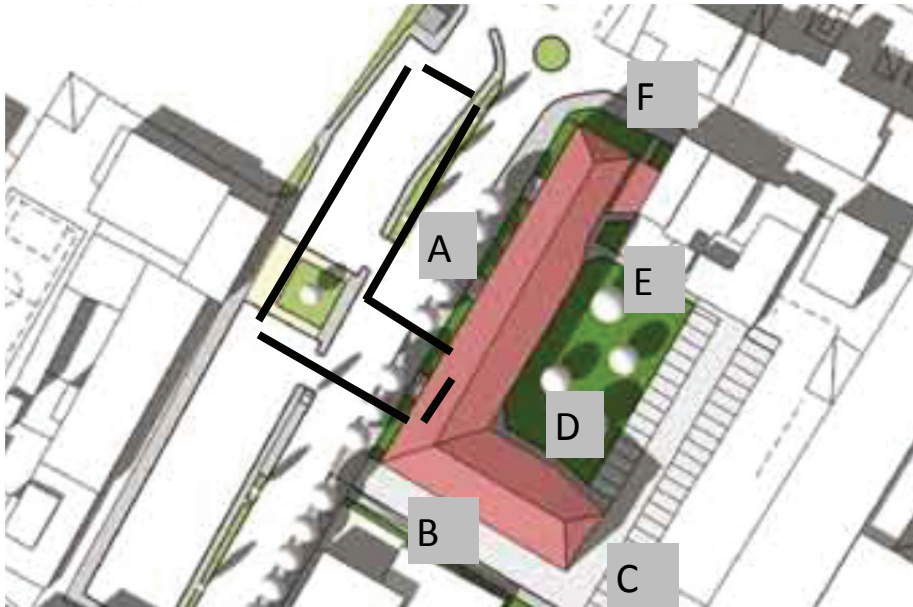

Figure 2.8: Typical Italian NZEB multi-family house.

Italian residential building reference is a multi-family residential building of four floors (three residential and one public) with a total of 29 flats, 4 staircases, and a civic centre at ground floor. Each flat has an average net indoor area (NIA) of 74 m² (NIA is about 85 % of GFA). The GFA of each flat is 87 m². Building envelope is composed as follows: exterior insulation and finishing system, double brick walls with thermal insulation in between, and internal finishing.

The global primary energy demand for non-renewable sources is 11.03 kWh/(m²_{NIA} yr), which meets the national requirement of 22.05 kWh/(m²_{NIA} yr).

Standard conditions for EP calculations

- 🏠 Indoor temperature (heating): 20 °C,
- 🏠 Indoor temperature (cooling): 26 °C,
- 🏠 Ground temperature: 15 °C,
- 🏠 DHW usage: 485 l/(m²yr),
- 🏠 Internal load from people: 1.5 W/m²,
- 🏠 Internal load from light and appliances: 3.5 W/m²,
- 🏠 Energy demand is converted to primary energy using the following factors:
 - 🏠 Gas: 1.05
 - 🏠 Electricity: 1.95
 - 🏠 Renewable on site: 1.0.

Envelope characteristics

The envelope is made up of heavy parts, resulting in an average heat capacity of 160 Wh/m²K.

- 🏠 Windows are primarily facing north-west and southeast with 136 and 128 m² respectively. Towards northeast and southwest there are 72 and 80 m² respectively. The windows have an average overall U-value of 1.46 W/m²K and the g-value (solar gain factor) is 0.67,
- 🏠 Facade U-value: 0.28 W/m²K,
- 🏠 Roof U-value: 0.26 W/m²K,
- 🏠 Slab on ground U-value: 0.27 W/m²K,
- 🏠 Indoor floors U-value: 0.53 W/m²K,
- 🏠 Floor between public space at ground floor and flats: 0.28 W/m²K,
- 🏠 Thermal bridges at foundations: 0.030 W/mK,
- 🏠 Thermal bridges around windows: 0.0 W/mK,
- 🏠 Information on air-tightness is not available.

Envelope characteristics

The envelope is made up of heavy parts, resulting in an average heat capacity of 120 Wh/m²K.

- 🏠 Window distribution is evenly, with 50 % (211 m²) at each primary facade, i.e. facing North and South respectively. The windows have an average overall U-value of 1.0 W/m²K and the g-value (solar gain factor) is 0.53,

- 🏠 Facade U-value: 0.15 W/m²K,
- 🏠 Roof U-value: 0.10 W/m²K,
- 🏠 Slab on ground U-value: 0.10 W/m²K,
- 🏠 Thermal bridges at foundations: 0.20 W/mK,
- 🏠 Thermal bridges around windows: 0.03 W/mK,
- 🏠 Air-tightness meets the BR18⁷ minimum requirements for new buildings, i.e. 1.0 l/m²s measured at a pressure difference of 50 Pa.

Technical building systems

- 🏠 Heating comes from a air-to-water heat pump, a gas boiler and PV panels (142 m² and 22 kWp). Heating supply in the flats is by radiators,
- 🏠 Heating for domestic hot water comes from the gas boiler and from thermal solar collectors (27 m²)
- 🏠 The building is naturally ventilated with an estimated ventilation rate of 0.2 l/s per m² of GFA, corresponding to about 0.3 air-change per hour.

Energy performance

The calculated primary energy demand is 25.4 kWh/(m²yr) distributed as:

- 🏠 Heating: 5.4 kWh/(m²yr),
- 🏠 DHW: 20.0 kWh/(m²yr),
 - 🏠 Net electricity (fans and pumps): 1.7 kWh/(m²yr).

Costs

- 🏠 Construction costs of building component: 1226 €/m²
- 🏠 Construction costs of technical building systems: 408 €/m²,

2.3.2. Calculation tools

The energy performance calculations of the different building configurations were carried out with EDILCLIMA , version EC700. The software implements the national technical specification UNI/TS 1300 series, based on CEN relevant standards and adapted for the specific Italian context and legislative framework.

⁷ Danish Building Regulations 2018

The calculation of heating and cooling needs is based on a quasi-steady-state calculation method with monthly heat balance and utilization factors in accordance with relevant national and EU standards. Input data on user behaviour, indoor climate and external climate can be tailored to evaluate energy performance of buildings taking into account standard (complying with energy certification scheme) or real operating conditions.

The tool allows the management of any type of technical system: heating systems and / or domestic hot water production, centralized and / or autonomous and their combinations. It is also possible to model all-air systems and mixed systems (for example: primary air and fan coils). The calculation of generation losses for traditional and / or modulating and / or condensing boilers can be carried out according to the three methodologies provided by the UNI / TS 11300-2.

Concerning mechanical ventilation systems, the program allows simulating extraction only, inlet only and balanced mechanical ventilation. The modelling of building components can be carried out both in graphical form and in tabular form. Envelope can be modelled using materials from the library or using the default building envelopes. The software allows calculating thermal transmittance of opaque structures according to the UNI EN ISO 6946.

The following energy calculations can be performed:

- 🏠 Heat load according to EN 12831, to size heating systems.
- 🏠 Heating and cooling needs, according to UNI/TS 11300-1, to evaluate the energy performance of the building envelope.
- 🏠 Primary energy for heating, domestic hot water, ventilation and lighting according to UNI/TS 11300-2.
- 🏠 Contributions from renewable sources (thermal solar, photovoltaic, biomass) according to UNI/TS 11300-4.
- 🏠 Primary energy for cooling according to UNI/TS 11300-3.

In this analysis the annual energy is computed for the following energy services: space heating, ventilation, domestic hot water production.

2.3.3. Solution set optimisation

In Italy, several climate zones exist and hence solution sets have been developed for two of these zones, namely Rome and Turin, representing a mild Mediterranean and a colder continental climate.

Rome

NZEB base case

The multilayer envelope is composed by two brick walls with an 8 cm EPS thermal coating. The ground floor is insulated with 4 cm of XPS. An additional insulating layer of EPS (4 cm) is included in the floor heating system. The rooftop is insulated with an XPS layer of 9 cm. Argon-filled double-glazed windows with aluminium frame are installed. Independently from equipment and occupants in real apartments, for the reference building the internal gains are set to 5 W/m² for sensible heat and 2.5 W/m² for latent heat, according to Italian standards. The building is naturally ventilated and, according the national building code, an air change rate of 0.3 h⁻¹ is considered (the value includes 0.6 occupancy factor).

The centralized heating system is controlled by outdoor and indoor climatic sensors with a three-ways valve. It consists of the following sub-systems: the room-controlled floor emission system, is fed by a 171-kW air water heat pump and a 94 kW condensing boiler, acting as a back-up system when outdoor temperatures drop below the working conditions of the heat pump. The cut-out temperatures of the heat pump are 3°- 45° and its coefficient of performance (COP) in standard conditions is 3.28. The heat supply systems are coupled to a 2000 litres inertial tank storage (8 m² surface, thermal conductivity 0.3 W/mK). The condensing boiler is also used for the domestic hot water (DHW) production.

Renewable energy sources consist of 15 m² vacuum tube solar thermal collectors for DHW production (coupled with a 4000 litres buffer tank storage) and a 22 kWp polycrystalline PV system (142 m²) both mounted on the tilted roof, on the south-east and south-west oriented pitches.

Solution sets, Rome

In all the following scenarios only two aspects of the envelope have been modified: the structure of the walls and the type of windows. Dry laid systems for the envelope are used instead of brick walls with extra coating insulation. The solution adopted is based on large autoclaved concrete bricks. The blocks can be sawn as if they were wood: they are light-weight, simple to lay, quick to assemble, simple to saw and file. The cost savings obtained when using this product is mainly due to the shorter construction time, lower maintenance costs, easiness of installation and lower number of workers employed. Transmittance of the walls is the same as in the base case. In all the four scenarios, the floor heating was replaced by other solutions. According to this, the insulation provided by the floor heating system was replaced with an additional layer of thermal insulation to respect the transmittance values required by the Standard.

Mono-block windows assembled window with its own roller shutter box are installed. U-value of the systems do not change respect to the standard technology, but lower construction time and easiness of installation are guaranteed. The mono-block window is delivered on the working site ready to assemble allowing to save money and time. Installation of these windows is easy even for non-specialized people.

It is worth to notice that, according to Italian Standards, the minimum peak power of PV installed does not depend on the real needs but on the surface area of the building. In the base case most electricity produced is not used by the building but it is sold to the grid. The following scenarios are aimed to maximize the direct use of electricity from PV panels either with electricity-driven solutions or by reducing the surface of PV panels installed (outlaw solution).

ITR-SS1

In this scenario the condensing boiler is used for both heating and DHW services. According to this the floor heating distribution system is replaced by aluminium radiators (efficiency 0.96). The use of condensing boilers and radiators allows to save money and reduce construction and maintenance costs: the architectural works for the construction of the floor heating system, the backbone lines of the floor heating system and the storage tank of the heat pump are eliminated. From the energy costs perspective, only gas is used. Furthermore, 34 m² of solar collectors are installed to achieve the minimum levels of energy production from renewable sources required by Legislative Decree 28/2011. The surface area of PV panels is the same as in the base case.

ITR-SS2

This is an electricity driven solution since the air water heat pump is used both for heating and DHW production. According to this, the condensing boiler is used as a backup system for both services. Furthermore the heating distribution is provided with low temperature aluminium radiators. These are more expensive than conventional aluminium radiators but lower expensive than floor heating. Construction savings in this scenario are guaranteed by the elimination of the floor heating system and of solar thermal collectors. In fact, in this case the minimum level of energy production from renewable sources are achieved only by means of the PV panels which feed the heat pump for both heating and DHW production. The surface area of PV panels is the same as in the base case.

From the energy costs perspective, expenses for gas are very few: gas is used only if condensing boiler works instead of the heat pump when outside temperatures are too low.

ITR-SS3

This electricity driven solution consists of eliminating the central heating supply and provide heating service with electric radiators in rooms. In this scenario most of electricity needed for electric radiators is provided by the PV panels. This solution is illegal since electricity from renewable sources cannot be counted for covering electric consumptions of heating production with Joule effect. DHW is provided by the condensing boiler.

Construction costs are considerably reduced since expenses for heating supply and distribution are avoided.

Solar thermal collectors and PV panels increased up to 33 m² and 163 m² respectively, in order to achieve the minimum levels of energy production from renewable sources required by Legislative Decree 28/2011. Basically, the highest technical expenses in this scenario are due the installation of renewable sources. Energy costs are equally balanced between gas and electricity. It is worth to notice that these scenarios have the highest electricity costs compared to the others: when energy from PV panels is not enough, much more electricity is taken from the grid for heating supply using electric radiators compared to the other solutions. Savings in building construction are balanced by higher energy costs in the operation phase.

ITR-SS4

This scenario provides the same solutions as scenario 1 except for the number of PV panels. In order to further reduce construction and maintenance costs, in this scenario only 10 m² of PV panels are installed. This value allows to achieve the minimum percentage of renewable energy production required by the Italian Standard and it is based on the real energy needs of the building, but it is an outlaw solution.

In fact, it does not respect the minimum peak power of PV required by the legislative decree 28/2011. Based on this regulation, at least 22 kWp should be installed as provided in the other scenarios.

Turin

NZEB Base case

The multilayer envelope is composed by two brick walls with a 13 cm EPS thermal coating. The ground floor is insulated with 7 cm of XPS. An additional insulating layer of EPS (4 cm) is included in the floor heating system. The rooftop is insulated with an XPS layer of 11 cm.

Argon-filled double-glazed windows with aluminium frame are installed. Independently from equipment and occupants in real apartments, for the reference building the internal gains are set to 5 W/m^2 for sensible heat and 2.5 W/m^2 for latent heat, according to Italian standards. A MVHR (Mechanical Ventilation with Heat Recovery) system supplies fresh filtered air into the building whilst retaining most of the energy that has already been used in heating the building.

The centralized heating system is controlled by outdoor and indoor climatic sensors with a three-ways valve. It consists of the following sub-systems: the room-controlled floor emission system, is fed by a 171 kW air water heat pump and a 94 kW condensing boiler, acting as a back-up system when outdoor temperatures drop below the working conditions of the heat pump. The cut out temperatures of the heat pump are 0° - 45° and its coefficient of performance (COP) in standard conditions is 3.28. The cut out temperature was set to 0° due to the low outdoor temperatures. It affects the efficiency of the heat pump, since the COP in operating conditions is much lower than in standard conditions. Nevertheless, seasonal performance factor is higher than the acceptability threshold defined by the Standards. The heat supply systems are coupled to a 2000 litres inertial tank storage (8 m^2 surface, thermal conductivity 0.3 W/mK). The condensing boiler is also used for the domestic hot water (DHW) production.

Renewable energy sources consist of 40 m^2 vacuum tube solar thermal collectors for DHW production (coupled with a 4000 litres inertial tank storage) and a 22 kWp polycrystalline PV system (142 m^2) both mounted on the tilted roof, on the south-east and south-west oriented pitches.

Solution sets, Turin

In all the following scenarios only two aspects of the envelope have been modified: the structure of the walls and the type of windows. Dry laid systems for the envelope are used instead of brick walls with extra coating insulation. The solution adopted is based on large autoclaved concrete bricks. The blocks can be sawn as if they were wood: they are light-weight, simple to lay, quick to assemble, simple to saw and file. The cost savings obtained when using this product is mainly due to the shorter construction time, lower maintenance costs, easiness of installation and lower number of workers employed. Two of the five scenarios maintain the same transmittance values of the building envelope as in the base case (scenarios 1 and 3), while the other three scenarios have a Super NZEB envelope. In Super NZEB scenarios, transmittances of the walls, roof and ground floor are lower than the values required in the Standards: 45 cm low-energy blocks are used for the walls; the rooftop is equipped with 27 cm of XPS thermal insulation; the ground floor is insulated with

19 cm of XPS and an additional insulating layer of EPS (4 cm) is included in the floor heating system.

In all the five scenarios, the floor heating was replaced by other solutions. According to this, the insulation provided by the floor heating system was replaced with an additional layer of thermal insulation to respect the transmittance values required by the Standard.

Mono-block windows assembled window with its own roller shutter box are installed. U-value of the systems do not change respect to the standard technology, but lower construction time and easiness of installation are guaranteed. The mono-block window is delivered on the working site ready to assemble allowing to save money and time. Installation of these windows is easy even for non-specialized people.

It is worth to notice that, according to Italian Standards, the minimum peak power of PV installed does not depend on the real needs but on the surface area of the building. In the base case most electricity produced is not used by the building but it is sold to the grid. The following scenarios are aimed to maximize the direct use of electricity from PV panels either with electricity-driven solutions or by reducing the surface of PV panels installed (outlaw solution).

ITT-SS1

The envelope of the building complies with the minimum NZEB requirements. In this low-tech thermal driven scenario, the condensing boiler is used for both heating and DHW services. According to this the floor heating distribution system is replaced by aluminium radiators (efficiency 0.96). The use of condensing boilers and radiators allows to save money and reduce construction and maintenance costs: the architectural works for the construction of the floor heating system, the backbone lines of the floor heating system and the storage tank of the heat pump are eliminated.

From the energy costs perspective, only gas is used. Furthermore, 79 m² of solar collectors are installed to achieve the minimum levels of energy production from renewable sources required by Legislative Decree 28/2011. A combined use of solar thermal collectors for both Heating and DHW is used: solar thermal collectors provide water preheating of condensing boiler feed water. The surface area of PV panels and the use of MVHR are the same as in the base case.

ITT-SS2

The envelope of this building has lower transmittance values than the NZEBs (Super NZEB scenario). The technical systems and the surface areas of renewable sources are the same as

in Scenario 1 apart from the ventilation service which is provided by a mechanical extraction ventilation system without heat recovery.

ITT-SS3

The envelope of the building complies with the minimum NZEB requirements. This is an electricity driven solution since the air water heat pump is used both for heating and DHW production. According to this, the condensing boiler is used as a backup system for both services. Furthermore, the heating distribution is provided with low temperature aluminium radiators. These are more expensive than conventional aluminium radiators but lower expensive than floor heating. Construction savings in this scenario are guaranteed by the elimination of the floor heating system and of solar thermal collectors. In fact, in this case the minimum level of energy production from renewable sources are achieved only by means of the PV panels which feed the heat pump for both heating and DHW production. The surface area of PV panels and the MVHR are the same as in the base case.

From the energy costs perspective, expenses for gas are lower than for electricity: gas is used only if condensing boiler works instead of the heat pump when outside temperatures are too low. This condition occurs more frequently in Turin than in Rome, although the cut-out temperature of the heat pump in Turin was lowered to 0° (in Rome it is set to 3°).

ITT-SS4

The envelope of this building has lower transmittance values than the NZEBs (Super NZEB scenario). The technical systems and the surface areas of renewable sources are the same as in Scenario 3 apart from the ventilation service which is provided by a mechanical extraction ventilation system without heat recovery.

ITT-SS5

The envelope of this building has lower transmittance values than the NZEBs (Super NZEB scenario). This electricity driven solution consists of eliminating the central heating supply and provide heating service with electric radiators in rooms. In this scenario most of electricity needed for electric radiators is provided by the PV panels. This solution is illegal since electricity from renewable sources cannot be counted for covering electric consumptions of heating production with Joule effect. DHW is provided by the condensing boiler.

Construction costs are considerably reduced since expenses for heating supply and distribution are avoided. The MVHR system is the same as in the base case.

Solar thermal collectors and PV panels increased up to 54 m² and 163 m² respectively, in order to achieve the minimum levels of energy production from renewable sources required by Legislative Decree 28/2011. Basically, the highest technical expenses in this scenario are due the installation of renewable sources.

Compared to Scenario 5, energy costs for gas in the base case are higher for two reasons: a lower number of solar collectors are installed, and gas is used also when condensing boiler works instead of the heat pump when outside temperatures are too low. On the contrary, in Scenario 5 energy costs for electricity are higher than the base case: for the electric radiators much more electricity is taken from the grid for heating supply compared to amount of electricity needed for the heat pump compressor.

2.3.4. Solution sets results summary

Table 2.4: Italian solution sets for Rome

Solution set results summary		Italian solution sets				
		Typical NZEB (base case) Rome	IT - SS1	IT - SS2	IT - SS3	IT - SS4
Rome						
All specific values relates to the NIA of the building						
Building envelope	Average U-value National comparison value: 0.61 W/m ² K	0.34	0.34	0.34	0.34	0.34
Net energy	Total	18.76	18.85	18.75	18.91	18.85
Final energy	Total EPBD	11.05	11.74	8.57	12.41	11.74
	Total (incl. other energy uses)	N/yr	N/yr	N/yr	N/yr	N/yr
Primary energy	Total EPBD ⁸ (from non-renewable sources)	11.03	12.33	5.91	14.66	12.43
	Total EPBD ⁹ (incl. both non-renewable and renewable sources)	25.42	24.8	27.78	29.62	24.9
Total (incl. other energy uses)		N/yr	N/yr	N/yr	N/yr	N/yr

⁸ Primary energy demand included in the national EPBD calculations.

⁹ Primary energy demand included in the national EPBD calculations.

Solution set results summary		Italian solution sets				
Rome	Typical NZEB (base case) Rome	IT - SS1	IT - SS2	IT - SS3	IT - SS4	
<p>All specific values relates to the NIA of the building</p>		<p>Low-tech thermal driven solution with variations in the composition of the external walls and the technology of the windows. Use of condensing boiler for both heating and DHW production.</p>	<p>Electricity driven solution with variations in the composition of the external walls and the technology of the windows. Heat pump for both heating and DHW supply. No use of solar thermal collectors.</p>	<p>Electricity driven solution with variations in the composition of the external walls and the technology of the windows. Electric radiators for heating supply. (Not legal).</p>	<p>Low-tech thermal driven solution (outlaw) with variations of the external walls and the technology of the windows. Use of condensing boiler for both heating and DHW production. Reduction of PV panels based on real needs. (Not legal).</p>	
	Energy costs	Total EPBD €/m ² yr	0.85	0.61	1.25	0.85
	Investment costs	Total (incl. other energy uses) Difference to typical NZEB €/m ²	N/yr -78	N/yr -67	N/yr -92	N/yr -93

Table 2.5: Italian solution sets for Turin.

Solution set results summary		Italian solution sets						
		IT - SS1	IT - SS2	IT - SS3	IT - SS4	IT - SS5		
Turin All specific values relates to the NIA of the building	Typical NZEB (base case) Turin	Low-tech thermal driven solution with variations in the composition of the external walls and the technology of the windows. Use of condensing boiler for both heating and DHW production. Combined use of solar collectors both for heating and DHW	Low-tech thermal driven solution with variations of the external walls and the technology of the windows and extra insulation. Use of condensing boiler for both heating and DHW production. Combined use of solar collectors both for heating and DHW. Mechanical extract ventilation.	Electricity driven solution with variations in the composition of the external walls and the technology of the windows. Air water heat pump for both heating and DHW supply. No solar collectors.	Electricity driven solution with variations in the composition of the external walls and the technology of the windows and extra insulation. Air water heat pump for both heating and DHW supply. No solar collectors. Mechanical extract ventilation.	Electricity driven solution (out-law) with variations in the composition of the external walls and the technology of the windows and extra insulation (SuperNZEB envelope). Electric radiators for heating supply. (Not legal).		
	Building envelope	Average U-value	0.30	0.24	0.30	0.24	0.24	
	Net energy	National comp. value: 0.59 W/m ² K	0.30	0.24	0.30	0.24	0.24	
	Final energy	Total	kWh/(m ² yr)	29.37	29.63	29.37	29.63	23.33
		Total EPBD	kWh/(m ² yr)	16.75	16.56	16.42	16.54	14.65
		Total (incl. other energy uses)	kWh/(m ² yr)					
	Primary energy	Total EPBD	kWh/(m ² yr)	37.64	36.53	47.39	45.4	42.72
		Total (incl. other energy uses)	kWh/(m ² yr)					
	Energy costs	Total EPBD	€/m ² yr	1.22	1.20	1.81	1.68	1.92
		Total (incl. other energy uses)	€/m ² yr					
Investment costs	Difference to typical NZEB	€/m ²	-63	-62	-65	-64	-56	

2.4. Slovenia

2.4.1. Typical building



Slovenian residential building reference is a compact multi-family house, which originates from the desire to provide high quality, corner placed and two-sides orientated dwellings that offer diverse views and good daylighting. The building is contains also several terraces and balconies. It has 5 floors and 21 flats with the average net floor area of 70.8 m², positioned around a central stairway. The typical building envelope consists of reinforced concrete walls for load bearing structure and ETICS¹⁰ facade, with a layer of external thermal insulation.

The calculated primary energy demand for the building is 44.3 kWh/(m²yr), which is considerably below the national NZEB requirement of 80 kWh/(m²yr).

Standard conditions for EP calculations

- 🏠 Indoor temperature (heating): 20 °C,

¹⁰ External Thermal Insulation Composite Systems

- 🏠 Indoor temperature (cooling): 26 °C,
- 🏠 Ground temperature: 10 °C,
- 🏠 Basement temperature: 15 °C,
- 🏠 DHW usage (at 60 °C): 300 l/(m²yr),
- 🏠 Internal load from people: 1.5 W/m²,
- 🏠 Internal load from light and appliances: 3.5 W/m²,
- 🏠 Energy demand is converted to primary energy using the following factors:
 - 🏠 Electricity: 2.5,
 - 🏠 District heating: 1.2,
 - 🏠 District heating with co-generation: 1.0
 - 🏠 Gas: 1.1,
 - 🏠 Fuel oil: 1.1,
 - 🏠 Wood biomass: 0.2.

Envelope characteristics

The envelope is made up of heavy parts, resulting in an average heat capacity of 120 Wh/m²K.

- 🏠 Window distribution is almost evenly, with 95 m² (37 %) facing south, 98.7 m² (38 %) north, 78.8 m² (24 %) west, and 96.2 m² (29 %) east. The windows have an average overall U-value of 1.3 W/m²K and the g-value (solar gain factor) is 0.6,
- 🏠 Facade U-value: 0.15 W/m²K,
- 🏠 Roof U-value: 0.10 W/m²K,
- 🏠 Slab on ground U-value: 0.14 W/m²K,
- 🏠 Thermal bridges are considered as an increase in the thermal conductivity of building envelope by 0.06 W/m² K
- 🏠 Air-tightness is 0.71 l/m²s measured at a pressure difference of 50 Pa.

Technical building systems

- 🏠 Heating, including domestic hot water, comes from a gas boiler supplemented by 190 m³ thermal solar collectors. Heating supply in the flats is by floor heating.
- 🏠 Heat losses from the heat and DHW distribution system inside the building is calculated to 0.62 kWh/(m²K),
- 🏠 De-central mechanical ventilation (SEL = 7.56 kJ/m³) with a supply ventilation rate of 1350 m³/h ≈ 0.30 h⁻¹).

Energy performance

The calculated primary energy demand is 44.3 kWh/(m²yr) distributed as:

- 🏠 Heating: 19.2 kWh/(m²yr),
- 🏠 DHW: 6.30 kWh/(m²yr),
- 🏠 Electricity: 18.8 kWh/(m²yr),
 - 🏠 Electricity (fans and pumps): 3.3 kWh/(m²yr).

Costs

- 🏠 Construction costs of building component: 581 €/m² ¹¹
- 🏠 Construction costs of technical building systems: 181 €/m² ^{11 12 13}
- 🏠 Maintenance costs:
 - 🏠 building component: 0.5 % of building component construction cost¹⁴,
 - 🏠 technical building systems: 1.5 % of TBS costs ¹⁴,
- 🏠 Annual design energy costs:
 - 🏠 Electricity for fans and pumps: 0.82 €/m² ¹⁵,
 - 🏠 Electricity for lighting: 0.32 €/m² ¹⁵,
 - 🏠 Heating: 1.16 €/m² ¹⁵.

2.4.2. Calculation tools

KI Energija is a software based on a national technical guideline for efficient energy use, which is prepared based on all relative EN ISO standards regarding buildings energy efficiency, e.g. SIST EN 13790, SIST EN ISO 13789 and other EPB standards, regulations and technical guides listed in Slovenian technical guide for energy efficiency use, which is the key document supplementing Slovenian Building code PURES 2010. The first step in calculation procedure is to select building location, with which also climate data is generated. Then, building's geometry needs to be defined (Net and gross heated volume and area, floor height, number of floors,...) and as well the indoor environment parameters, such as indoor temperature in winter and summer period, humidity, internal gains (W/m²). At this point also, the type of ventilation needs to be defined. In the next steps the software requires building's envelope characteristics: U-value of external, walls, roof, floor, windows and their area and orientation. Besides, also internal constructions and thermal bridges need to be

¹¹ Dekleva A. 2017. Projekt za pridobitev gradbenega dovoljenja. Stanovanjska soseska Novo Brdo, Funkcionalna enota E2. Ljubljana.

¹² <https://www.ekosklad.si/>

¹³ FP7 EE HIGHRISE (Eco Silver House)

¹⁴ Rules on standards for the maintenance of apartment buildings and apartments, Official Gazette of the Republic of Slovenia, no. 20/04 and 18/11. <http://www.uradni-list.si/1/objava.jsp?urlid=200420&stevilka=878>

¹⁵ <https://www.stat.si/StatWeb/Field/Index/5/30> (30.3.2018)

defined to calculate the building energy performance properly. In the last steps, building systems must be defined in order to perform the calculation. For heating and domestic hot water, the software offers the “wizard”, which helps to easier define the building systems. In addition, it is required to define cooling, renewable energy sources and lighting, where the installed power of lights and their operating hours need to be specified.

The result of the calculation are the detailed data on building energy performance and needed also for the calculated energy performance certificate (EPC) and a more detailed report on building’s energy performance for heating zone defined in the beginning of the calculation.

2.4.3. Solution set optimisation

SL-SS1

In the Slovenian solution set 1 heating and domestic hot water (DHW), system with gas condensing furnace generation was changed with the district heating system. The latter contribute to higher percentage of renewable energy sources (RES) and also to lower maintenance costs of building systems. Instead of hygro-sensible ventilation, decentral mechanical ventilation with 85 % heat recovery was implemented. Moreover, better airtightness (from $n_{50}=2$ to $n_{50}=1$) was predicted. Both measures result in much lower ventilation losses and gained returned energy, which lead to lower heating demand and consequently to lower heating costs, even though the price of district heating is higher than gas costs. However, due to higher electricity costs and DHW costs, the operational costs are expected to be approximately 5 % higher in comparison with the reference building.

SL-SS2

Besides the usage of decentral mechanical ventilation with 85 % heat recovery instead of hygro-sensible ventilation and better airtightness (from $n_{50}=2$ to $n_{50}=1$), in this solution set three additional measures were used. Namely, the air to water heat pump changed the condensing gas boiler for heating and DHW system, double glazing windows were changed with triple glazing windows and also better airtightness was predicted. The investment costs were a bit higher than in SS1, but the net heating energy reduced for 30 %. Additionally, the RES percentage went up to 55 %, due to the implementation of air-to-water heat pumps, which contributed also to the lower operational costs.

SL-SS3

In the third Slovenian solution set, SS3, DHW system generation was changed with the air to water heat pump, the heating system is still powered by gas condensing furnace. Also, similar to SS2, triple glazing windows, decentral mechanical ventilation with 85 % heat recovery and also better airtightness (from $n_{50}=2$ to $n_{50}=1$) were used. Because of lower electricity use the entire operational costs are basically the same as in SS2, but still lower than in SS1 and reference building. This solution set has the highest maintenance costs in comparison to all other solution sets and reference building.

SL-SS4

The fourth Slovenian solution set, SS4, has the same idea as SS2, however in this case also PV is included. This solution set has the highest investment cost, but the building itself is quite self-sufficient. So, in this case air to water heat pump was used for heating and DHW system, triple glazing windows were implemented alongside with better airtightness (from $n_{50}=2$ to $n_{50}=1$). The key difference in comparison to all other solution sets and reference building are the RES percentage and operational costs. The SS4 has the least operational costs (2 – 3 times less) and the highest RES percentage.

2.4.4. Solution sets results summary

Table 2.6: Slovenian solution sets summary.

Solution set results summary Slovenia		Slovenian solution sets				
		Typical NZEB (base case)	SI- SS1	SI-SS2	SI-SS3	SI-SS4
All specific values are related to the conditioned floor area of the building.			District heating as generation for heating and DHW; Use of mechanical ventilation with 85 % heat recovery; better airtightness	Air heat pump as generation for heating and DHW; Use of mechanical ventilation with 85 % heat recovery; Triple glazing windows; better airtightness	Air heat pump as generation for DHW; Gas furnace condensing for heating; Use of mechanical ventilation with 85 % heat recovery; Triple glazing windows; better airtightness	Air heat pump as generation for heating and DHW; Roof PV panels; Use of hygro-sensible ventilation system; Triple glazing windows; better airtightness
Building envelope	Specific coefficient of transmission thermal losses H'_T National comparison value $H'_{T,max}: 0.473 \text{ W/m}^2\text{K}$	0.413	0.413	0.333	0.333	0.333
Net energy	Total kWh/(m ² yr)	40.1	31.5	27.5	27.5	35.7
Final energy	Total EPBD kWh/(m ² yr)	49	40.8	35	35.6	43
	Total (incl. other energy uses) kWh/(m ² yr)	N/A	N/A	N/A	N/A	N/A
Primary energy	Total EPBD kWh/(m ² yr)	44.3	59.9	39.9	43.1	3.4
	Total (incl. other energy uses) kWh/(m ² yr)	N/A	N/A	N/A	N/A	N/A
Energy costs	Total EPBD €/m ² yr	3.19	3.42	2.39	2.43	1.1
	Total (incl. other energy uses) €/m ² yr	N/A	N/A	N/A	N/A	N/A
Investment costs	Difference to typical NZEB €/m ²	762	-65	-32	-18	-5

2.5. Solution sets summary

Based on identification of a typical NZEB residential building in each of the participating countries, solutions sets that can potentially reduce the investment cost while at least maintaining the overall energy performance have been identified. Analyses of the solution sets was carried out using national tools for proving compliance with energy performance requirements.

The focus of the work done in this section of the report was to identify solution sets that reduce the construction and/or operational cost for NZEBs while at the same time maintaining the level of operational primary energy needed in the building. In this context, a solution set is a combination of different measures to the building envelope and/or technical building systems - e.g. reduced façade insulation in combination with rooftop PV - that in total delivers the same energy performance, but at lower investment costs. Each of the participating countries have analysed several candidate solution sets, in e.g. Germany eight different sets, before selecting the ones presented in the project deliverable.

The solution sets are:

🏠 Denmark:

1. High efficiency insulation in exterior walls resulting in lower construction cost for foundations, window fittings and roofs.
2. Reduced insulation in walls, roof and floor; Roof PV panels, DHW solar heating, Decentral mechanical ventilation, efficient water fixtures.
3. Reduced insulation in walls, roof and floor; Roof PV panels; DHW solar heating.
4. Four-layer windows; Water saving fixtures; Natural ventilation (illegal).
5. Reduced insulation in walls, roof and floor; Decentral mechanical ventilation; Heat recovery on grey wastewater.

🏠 Germany:

1. Decentral direct electric heating (e.g. heated glass or marble plates) and decentral direct electric DHW system, decentral ventilation system with heat recovery, roof PV panels, heat recovery from shower waste water and reduced insulation level.
2. Central supply and exhaust ventilation and heating system with air-air heat pump, decentral electrical DHW heater and heat recovery from shower waste water and reduced insulation level.
3. Central combined heating and DHW system with district heating, central exhaust ventilation system and reduced insulation level.

4. Central heating system with exhaust air-water heat pump in central exhaust ventilation system supported by condensing gas boiler, decentral DHW heat exchange modules, roof PV panels and reduced insulation level.

🏠 Italy, Rome:

1. Thermal driven solution with variations in the composition of the external walls and the technology of the windows. Use of condensing boiler for both heating and DHW production.
2. Electricity driven solution with variations in the composition of the external walls and the technology of the windows. Heat pump for both heating and DHW supply. No use of solar thermal collectors.
3. Electricity driven solution with variations in the composition of the external walls and the technology of the windows. Electric radiators for space heating mainly supplied by the PV panels (not compliant with EP requirements for using PV panels to directly feed electric systems of heating). According to the legislative decree 28/2011 energy from PV panels cannot be counted for the contribute of renewable sources if they directly feed electric systems for heating, DHW or ventilation services.
4. Low-tech thermal driven solution with variations in the composition of the external walls and the technology of the windows. Use of condensing boiler for both heating and DHW production. Reduction of PV panels based on real needs: this is illegal in Italy since standard requires a minimum amount of PV panels as a function of building surface area.

🏠 Italy, Turin:

1. Low-tech thermal driven solution with variations in the composition of the external walls and the technology of the windows. Use of condensing boiler for both heating and DHW production. Combined use of solar collectors both for heating and DHW.
2. Low-tech thermal driven solution with variations in the composition of the external walls and the technology of the windows and extra insulation (super NZEB envelope). Use of condensing boiler for both heating and DHW production. Combined use of solar collectors both for heating and DHW. Mechanical extract ventilation.
3. Electricity driven solution with variations in the composition of the external walls and the technology of the windows. Air water heat pump for both heating and DHW supply. No solar collectors.
4. Electricity driven solution with variations in the composition of the external walls and the technology of the windows and extra insulation (super NZEB envelope).

Air water heat pump for both heating and DHW supply. No solar collectors.
 Mechanical extract ventilation.

5. Electricity driven solution with variations in the composition of the external walls and the technology of the windows and extra insulation (super NZEB envelope). Electric radiators for space heating mainly supplied by the PV panels (not compliant with EP requirements for using PV panels to directly feed electric systems of heating).

🏠 Slovenia:

1. District heating as generation for heating and DHW; use of mechanical ventilation with 85 % heat recovery; better airtightness.
2. Air heat pump as generation for heating and DHW; use of mechanical ventilation with 85 % heat recovery; triple glazing windows; better airtightness
3. Air heat pump as generation for DHW; condensing gas boiler for heating; use of mechanical ventilation with 85 % heat recovery; triple glazing windows; better airtightness.
4. Air heat pump as generation for heating and DHW; roof PV panels; use of hygro-sensible ventilation system; triple glazing windows; better airtightness

In the solutions sets shown above, decrease of the insulation level at the thermal envelope is one of the common features. This is natural when considering the resulting cost reductions that include: lower costs for insulation material, lower costs for windows, smaller facade area, smaller foundations and roof if maintaining the same habitable area.

Replacement of traditional heating systems with less costly ones are also among the solutions. In some cases this is not legal due to national legislation that e.g. prohibits direct use of electricity for space heating.

In NZEBs, domestic hot water is one of the prime contributors to the buildings energy demand. And in some solution sets, water saving fixtures or heat recovery on the grey waste water have been used to reduce the energy demand for domestic hot water. This opens for use of less efficient solutions elsewhere in the building and thus lowering the investment costs.

Reductions in investment costs range from 1 €/m² (but with a slightly better energy performance) to 94 €/m², with the highest cost savings in an Italian solution set. The solution sets can obviously not be compared directly across climate zones and national legislation. However, it is envisaged that some solutions in another country's solution set may inspire to new combinations and hence new solution sets.

2.5.1. Possible solution sets used across borders

In this section possible solutions from other countries are evaluated for possible use in the four countries.

Denmark

Use of decentral electrical resistance heating (German and Italian solution sets) has a potential for lowering the cost of NZEBs in Denmark. However, due to the differences in primary energy factors for district heating vs. electricity it will be difficult to meet the energy performance requirements in electrically heated buildings. Saved cost for the heating system could be used for improved energy performance elsewhere in the building and in this way potentially lower the investment cost while maintaining the primary energy performance.

Germany

The transfer of solution sets has to take into account the different starting points (base cases) in the country. That means for Germany that for example solution sets focussing on the addition of solar thermal are not attractive because this technology is already included in the base case, also because of the general requirement to apply renewable energy systems (EEWärmeG). It is also difficult to transfer a complete solution set because of the different base cases. More efficient insulation material or windows with 4-layer glazing have to be evaluated in comparison with the base case using national costs. Therefore, the transfer is not too easy.

Interesting technologies (parts of the solution sets) for the German market are according to the view of the German CoNZEBs team:

- 🏠 Water saving fixtures: However two points have to be considered:
 - 🏠 They will result in a slightly reduced comfort
 - 🏠 They have no impact in the current German calculation method, which defines the DHW to $15 \text{ kWh}/(\text{m}^2_{\text{NFA}}\text{yr})$ independent on the type of fixtures. Thus they can't be compensated with lower insulation or similar
- 🏠 Roof PV: This will have a positive impact on electricity-driven systems (e.g. ventilation or direct electrical heating). It is already part of two German solution sets. However, with the upcoming revision of the German energy ordinance it cannot be accounted for direct electrical heating anymore.
- 🏠 Direct electrical heating, hygro-sensitive (demand-controlled) ventilation are also part of some of the German solution sets
- 🏠 Optimisation of the thermal quality of the building envelope (balance between U-values of windows, walls, roof, cellar, and ceiling): The German solution sets have focus on

alternative technologies. It can be assumed though, that an optimisation of different building envelope U-values can result in slightly lower investment costs. However, this is depending on the actual case, location and time of the building construction and is difficult to predict in general.

- 🏠 Improved airtightness: The impact of a better airtightness can be calculated with the German energy performance methodology and will lead to lower requirements at other building parts (e.g. U-values of the building envelope). If investment costs are considered only this will lead to savings in the German case as well. On the other hand it will lead to probably higher planning costs and costs for the airtightness test (blower door or similar). The blower door test is however required anyway if a ventilation system is accounted for in the energy performance calculation.

Italy

The use of solution sets developed in the other participant countries is strictly related to the Italian NZEB definition and requirements, as well to the climatic conditions, that are substantially different, especially for Rome. Without taking into account the specific values referring to the technologies contained in a specific solution set, but considering the general approach, the following considerations apply:

- 🏠 Danish solution sets. DK-SS1 is a potential applicable solution that should be double-checked with costs of high performing insulation materials. Solutions DK-SS2, DK-SS3 and DK-SS5 should be carefully addressed since the combination of ventilation with heat recovery to be re-paid by less insulation might be not cost efficient in most north Italian applications and, for sure, not in Mediterranean climates like Rome. DK-SS4 is not suitable, due to high costs of such performing windows, which do not provide significant savings at Mediterranean latitudes.
- 🏠 Concerning the German solutions, solutions GER-SS2, GER-SS3 and GER-SS8 have focus on recovery and fresh stations from DHW but this has limited advantages in Italy because of the mandatory use of renewable energies, with solar thermal for DHW among the most effective. The solution GER-SS7 has potential applications in buildings, located in area where district heating with sufficiently low primary energy factor (to be certified by the company providing the service).
- 🏠 The Slovenian solutions appear not cost effective for Italy, due to high performance ventilation with heat recovery and works on increased air-tightness, which are not so common in Italy. SI-SS4 has higher potential applications, especially in Turing, where ventilation and triple glazing unit are better justified by climatic conditions.

Slovenia

DK-SS2 could be adopted and used also in Slovenia, especially due to the usage of PV panels and DHW solar heating, which present a good solution for achieving necessary renewable energy source (RES) ratio. This solution set foresees the usage of de-central mechanical ventilation, which is also used in the Slovenian typical NZEB. Also, the use of energy efficient taps could be adopted in Slovenia. Currently the use of energy efficient taps is required in green public procurement regulation for public buildings only. However, in Slovenian social housing the energy used for domestic hot water (DHW) is quite big. The implementation of energy efficient taps in social housing presents a good potential for reducing the energy used for DHW and water savings.

IT-SS2 is also a solution set that could be used in Slovenian market. The key technology that is interesting the use of autoclaved aerated concrete blocks, which nowadays are less commonly used as the brick walls are. The use of heat pumps in this solution set presents the technology with raising importance, due to growing share of RES in grid electricity and due to regulation of supported self-supply with PV.

3. Description of special technologies used in NZEB solution sets

In the following sections, descriptions of the technologies used in the national solution sets are described. However, only those technologies that are not commonly known have been described.

Some technologies are describe in some detail, while others are described more generally and generic. Bold text in Table 3.1 indicates technologies described in detail and italics are technologies with a general description.

At the end of each technology description, there is a local list of relevant references, valid for the specific technology only.

Table 3.1: A summary of technologies used in national solution sets.

	Text	DK-typ	DK-SS1	DK-SS2	DK-SS3	DK-SS4	DK-SS5	DE-typ	DE-SS2	DE-SS3	DE-SS7	DE-SS8	IT-typ	ITR-SS1	ITR-SS2	ITR-SS3	ITR-SS4	ITT-SS1	ITT-SS2	ITT-SS3	ITT-SS4	ITT-SS5	SI-typ	SI-SS1	SI-SS2	SI-SS3	SI-SS4	
Envelope	Autoclaved aerated concrete													x	x	x	x	x		x								
	Mono-block windows													x	x	x	x	x	x	x	x	x						
	Reduced insulation, facade			x		x	x		x	x	x	x																
	Reduced insulation, roof			x		x	x		x	x	x	x																
	Reduced insulation, ground floor			x		x	x		x	x	x	x																
	Improved insulation, facade		x																	x		x	x					
	Increased ground floor insulation																			x		x	x					
	Improved insulation, roof																			x		x	x					
	2-layer windows								x	x	x	x																
	3-layer windows		x					x																		x	x	x
	4-layer windows					x																						
Increased airtightness																								x	x	x	x	
Ventilation	MVHR	x																	x		x			x	x	x	x	
	MVHR, moisture controlled									x														x	x	x	x	
	Decentral ventilation + HR					x	x		x																			
	Exhaust ventilation + HP											x																
	Exhaust ventilation without HR							x			x																	
	Hybrid mechanical and NV				x																							
DHW	Exhaust air HP -> air									x																		
	Energy efficient taps						x																					
	HR Gray waste water				x				x	x																		
Generation	Electric DHW heating								x	x																		
	District heating and DHW	x	x	x	x	x	x				x													x				
	HP air-water, heating & DHW														x						x	x				x	x	
	Exhaust air HP -> heating												x															
	Exhaust air HP -> DHW												x															
	Condensing gas boiler							x						x	(x)	x	x	x	x	x	(x)	(x)	x				x	
Heating	HP air, DHW																									x		
	Heating via ventilation system									x																		
Cooling	Electric emitters								x					x	x	x	x	x	x	x	x	x						
	In any form																											
RES	PV panels on roof						x		x			x				x	(x)						x				x	
	Solar heating, DHW			x					-	-	-	-		x	-	x	x				-	-	x					
	Solar heating, heating & DHW							x											x	x								
	Heat pump									x		x			x						x	x				x	x	x
	Explanation:	x	Different from typical building																									
		-	Removed compared to the typical building																									
		(x)	Reduced compared to typical building																									

3.1. Building envelope

3.1.1. Autoclaved aerated concrete blocks

The role of thermal insulation of building facades is very important to achieve NZEB targets, to do so a number of requirements must be complied with: thick insulation layers, multi-layered systems, special care in managing and avoiding thermal bridges. The proposed solution allows reducing the construction costs, keeping high energy standards.

The technology dates back to 1920's, when it was first developed in Sweden. The raw materials are those of the conventional concrete (cement, lime, water, sand and a small content of aluminium powder), but the manufacturing process gives the product high insulation properties. The materials are mixed together and ripened, during the latter a chemical reaction takes place accompanied by the production of micro air bubbles, which remain entrapped inside the concrete matrix. In the latter stage, the raw semi-solid block is hardened and precisely cut in autoclave with temperature below 200 °C.

Main properties of an autoclaved aerated concrete (AAC) blocks, 624 mm long and 199 mm high, as manufactured by Ytong [1], are presented in Table 3.2. Thermal transmittance values refer to the blocks only, without taking into account the additional thermal resistance of internal and external plaster layers; such values are also calculated in dry conditions, potential increase of thermal conductivity must be calculated according to reference technical standards, as a function of design conditions. It has to be noted, that other construction elements as lintels and roof-reinforced slabs can be manufactured with the same technology. The values here presented are exemplary of a specific manufacturer, differences in geometry, applications and properties might apply for other commercial products [2, 3]

Table 3.2: Thermal properties of autoclaved aerated concrete blocks.

Thickness [mm]	Dry thermal conductivity [W/mK]	Dry density [kg/m ³]	Thermal transmittance [W/m ² K]
24	0.078	325	0.31
30	0.078	325	0.25
36	0.078	325	0.21
40	0.072	300	0.17
45	0.072	300	0.16
48	0.072	300	0.15

The product beside the good insulation properties also ensures good performance during the cooling season; as an example, the periodic thermal transmittance of the block, for

whatever thickness, comply with the requirements of envelope components set in the Italian building regulation.



Figure 3.1: Facade built using the autoclaved aerated concrete blocks.

A crucial issue about this technology is that the facade is built in a single working cycle (brickwork), while most common alternative technologies need at least two cycles, e.g. as it happens for brickwork and external insulation; in both cases, extra time for finishing layers has to be taken into account. The construction process is also made more efficient thanks to the block handles, which make it easier to lift and properly place the product. Moreover, these blocks have a lower wastage respect to alternative brickworks, 5 % of the former about 8 % for conventional clay bricks.

Advantages and disadvantages

- ⊠ Construction time significantly decreases respect to other construction technologies, not based on pre-fabrication.
- ⊠ Construction costs are lower respect to other common facade technologies.
- ⊠ Single layer continues brickworks minimise the effect of thermal bridges
- ⊠ Restraints may apply at national level if these blocks are also used for structural functions.
- ⊠ For very low thermal transmittance requirements, additional insulation layers might be required, making this solution less cost effective.

Energy performance

The dry thermal conductivity is in the 0.07 - 0.08 W/mK, while thermal transmittance is in the 0.31 - 0.15 W/m²K range. Comparison versus other technologies should be carried out in terms of delta cost for envelope solutions with the same thermal transmittance or, conversely, in terms different insulation performances for the same cost investments.

Financial data: investment, operation and maintenance

- 🏠 Construction (*delivery and installation*):
 - 🏠 Costs can be significantly different for the different countries and, in some cases, among the single country. Concerning the labour, costs should refer to official pricelists of workers with brickwork skill. Prices can also vary according to the size of the work.
- 🏠 Maintenance:
 - 🏠 No maintenance data are available, however due to the simplicity of the technology and durability of the materials, it is estimated that costs should be lower than other technological solutions for building facades.
- 🏠 Operation:
 - 🏠 No special requirements.

Environmental issues

Concerning the environmental issue, environmental product declaration (EPD) are available for the Ytong blocks, however it is interesting a comparative analysis between this technology and alternative solutions for building opaque facades. Since no EPDs were available for the alternative technologies, the comparison, carried out by the Polytechnic School of Milan, referred to Econinvent 2.2 database [4]. Concerning the PEI (primary energy indicators, including embodied energy) the following results were collected for different envelope configurations: AAC block about 400 MJ/m², two clay bricks layers with insulation in air gap and clay brick layer plus ETICS about 800 MJ/m², light dry laid envelope system more than 1000 MJ/m². In terms of GWP (global warming potential) expressed in terms of equivalent CO₂ kilograms, it was found that AAC and ETICS scored about 60 eq.CO₂ kg/m², the other two systems close to 60 eq.CO₂ kg/m².

Development potential

The technology is mature and well present on the market.

References

- [1] Ytong - ecologia e risparmio energetico - Il sistema costruttivo in calcestruzzo cellulare, (Ytong - ecology and energy savings - The autoclaved aerated concrete construction systems)
https://www.ytong.it/it/docs/Broch_Sistema_Compl_Rev2.pdf.
- [2] Autoclaved aerated concrete (AAC, Aircrete), <https://www.understanding-cement.com/yrutoclaved-aerated-concrete.html#>.
- [3] Autoclaved Aerated Concrete, <https://www.cement.org/cement-concrete-applications/paving/buildings-structures/concrete-homes/building-systems-for-every-need/yrutoclaved-aerated-concrete>.
- [4] A. Campioli, M. Lavagna, M. Paleari, Ricerca sulla caratterizzazione ambientale dei sistemi costruttivi minerali ytong e multipor (Research on the environmental characterisation of Ytong and Multipor construction systems), <https://www.ytong.it/it/docs/Brochure-Sostenibilita.pdf>.

3.1.2. Mono-block windows

Windows strongly influence the energy performance of residential buildings for space heating, while cooling performances are mainly improved by solar shading systems, which are not strictly part of the window itself. Cost reduction potentials are limited, since there is an evident correlation between the cost of the product and its main energy performance indicator: the thermal transmittance, namely U-value. Cost reduction due to the delocalization of manufacturing of course cannot be taken into account, since the comparison should be carried among the same product category. Cost reductions can be pursued, consequently, more on the construction technology than on performances.

Windows consist of:

- 🏠 the sub-frame, generally metallic or in wood, mounted on the hole of the façade, on which the window is secured;
- 🏠 the window, with its fixed and moveable parts;
- 🏠 the shutter box, placed above the window;

It has to be noted that nowadays most companies already produce the window and its shutter box a single element. However real cost reductions can be achieved by mono-block

windows, which are placed directly in the hole of the facades, saving money for sub-frames manufacturing and associated brickworks for mounting. The mono-block windows also have insulation around the structure, thus minimizing the window to wall thermal breaks, while no differences apply in terms of thermal transmittance between standard or mono-block windows manufactured using the same components (glazings and frames). Such windows can be made with aluminium or PVC.

Figure 3.2 shows the hole in the whole, without the sub-frame, used for mono-block windows, on the left, while on the right is presented a schematic section of an aluminium mono-block window manufactured by Giuliani srl in Italy. Figure shows the design detail of a mono-block window of the above cited manufacturer [1].

Concerning the cost reductions potential, a simulation study was carried out by Giuliani srl and ENEA for a supply of windows with aluminium frame with thermal-break frames and low-e double glazing units (thermal transmittance of the window $1.3\text{W}/\text{m}^2\text{K}$) in a new multi-family house. The analysis was carried out considering two equivalent product typologies (mono-block and conventional) both produced by the company, and the mono-block windows resulted 20 % cheaper.



Figure 3.2: Hole in the whole for mono-block window, left, and a section of a mono-block window by Giulian srl, Italy

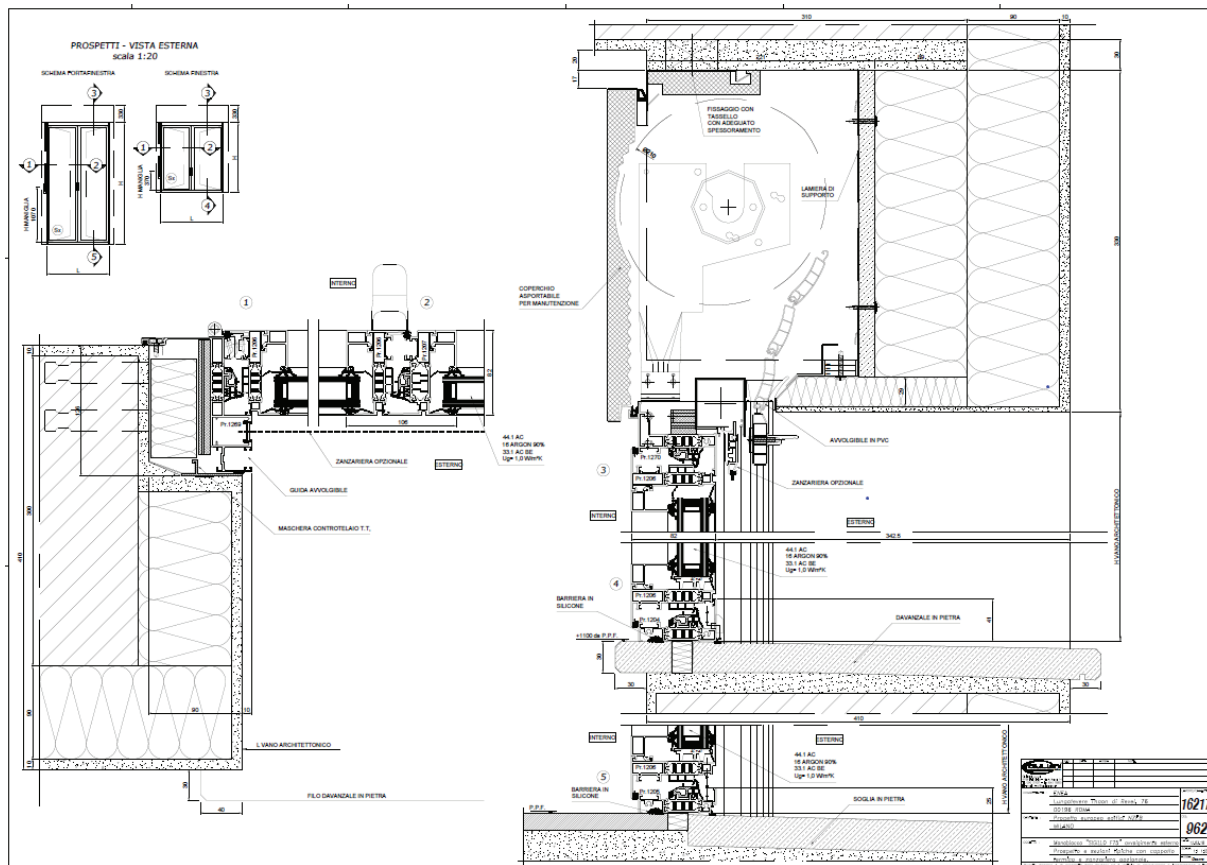

Figure 3.3: Facade built using the mono block window system by Giulian srl, Italy.

Advantages and disadvantages

- 🏠 Cost reduced.
- 🏠 Construction time reduced further than cost, thanks to avoiding masonry works for sub-frame mounting.
- 🏠 Improved management of window to wall thermal bridges.
- 🏠 Aesthetics can be a problem for cheaper products
- 🏠 Masonry works have to be very precise, otherwise the mono-block mounting can get difficult and not effective.

Energy performance

Energy performances for equivalent windows, conventional and mono-block, do not change, once the target value is defined. Thermal breaks at the wall/window junction need to be analysed for the specific case

Financial data: investment, operation and maintenance

- 🏠 Construction (*delivery and installation*):
 - 🏠 Costs can be significantly different for the different countries and, in some cases, among the single country. It is important to compare costs of mono-block and conventional windows for the single manufacturer; in fact windows costs are subject to enormous fluctuations depending on products, brands, local market conditions, experience of installers.
- 🏠 Maintenance:
 - 🏠 No maintenance data are available.
- 🏠 Operation:
 - 🏠 No special requirements once the windows are mounted.

Environmental issues

Mono-block windows are generally made with aluminium or PVC, which determine the environmental performance of the window, assuming the glazing unit as invariant in the system. In a study it was found out that, for 1.2×1.2m window, aluminium has the highest embodied energy (about 6 GJ), doubling the PVC windows, whose embodied energy amounts to 2980MJ [2].

Development potential

The technology is mature and well present on the market, however the building integration (indoor and outdoor aesthetics) remain an issue for higher market penetration.

References

- [1] Personal communication by Giuliani Soc. Coop., <http://www.giulianisc.it>
- [2] M. Asif, A. Davidson BSc and T.Muneer, Life cycle of window materials a comparative assessment, School of Engineering , Napier University, 10 Colinton Road, Edinburgh EH10 5DT, U.K.

3.1.3. Reduced insulation

Reduced insulation thickness in the facades of a building result in reduced costs in terms of:

- ⊞ Reduced cost for foundations (smaller foundation to carry the more slender facade construction),
- ⊞ Reduced cost for integration (construction) of windows into the facade,
- ⊞ Reduced cost for roofs,
- ⊞ Alternatively, increased net habitable area inside the building with the same build-up area.

Obviously, the reduced insulation level needs to be compensated by other energy saving measures elsewhere in the building in order to maintain the overall energy performance. The overall investment cost may reduce by utilising a combination of reduced insulation and other measures.

3.1.4. Improved/increased insulation

Use of more efficient insulation materials in the facade of a new building may result in reduced costs (see above) or increased habitable area for the same build-up area.

More efficient insulation materials (compared to fibre materials) are normally based on extruded foam materials. Expanding the foam are in most cases done by infusion of gasses into the enclosures of the foam. However, this gas may over time diffused from the foam hence reducing the initial insulation efficiency of the material.

3.1.5. Windows with 2/3/4 layers of glass

Low energy windows are normally composed by 2, 3, or more layers of glass and/or foils, whereas some have a low emission coating and the cavities are filled with a noble gas. This results in a transparent construction with low heat transmission coefficient and a reasonable solar gain coefficient. Most modern window systems have the capability of providing a positive heat balance over the heating season, i.e. letting more solar energy into the building compared to the thermal heat loss.

Experiences show that windows produced in large quantities becomes cheaper than windows produced in smaller quantities. If legislation requires a certain level of energy efficiency for new windows in new and existing buildings, windows that comply with these requirements often becomes cheaper than other types of windows, even windows with poorer energy performance.

3.1.6. Increased airtightness

Sufficient airtightness reduces leakage through the building envelope into the building, which has a considerable impact on the energy loads and consequently energy demand and energy costs of buildings. Air infiltration happens through various openings and venues in the building varying from large openings such as doors and windows to minute cracks and crevices. In addition to influencing building energy losses, infiltration affects also indoor air quality and can result in moisture accumulation in the building envelope.

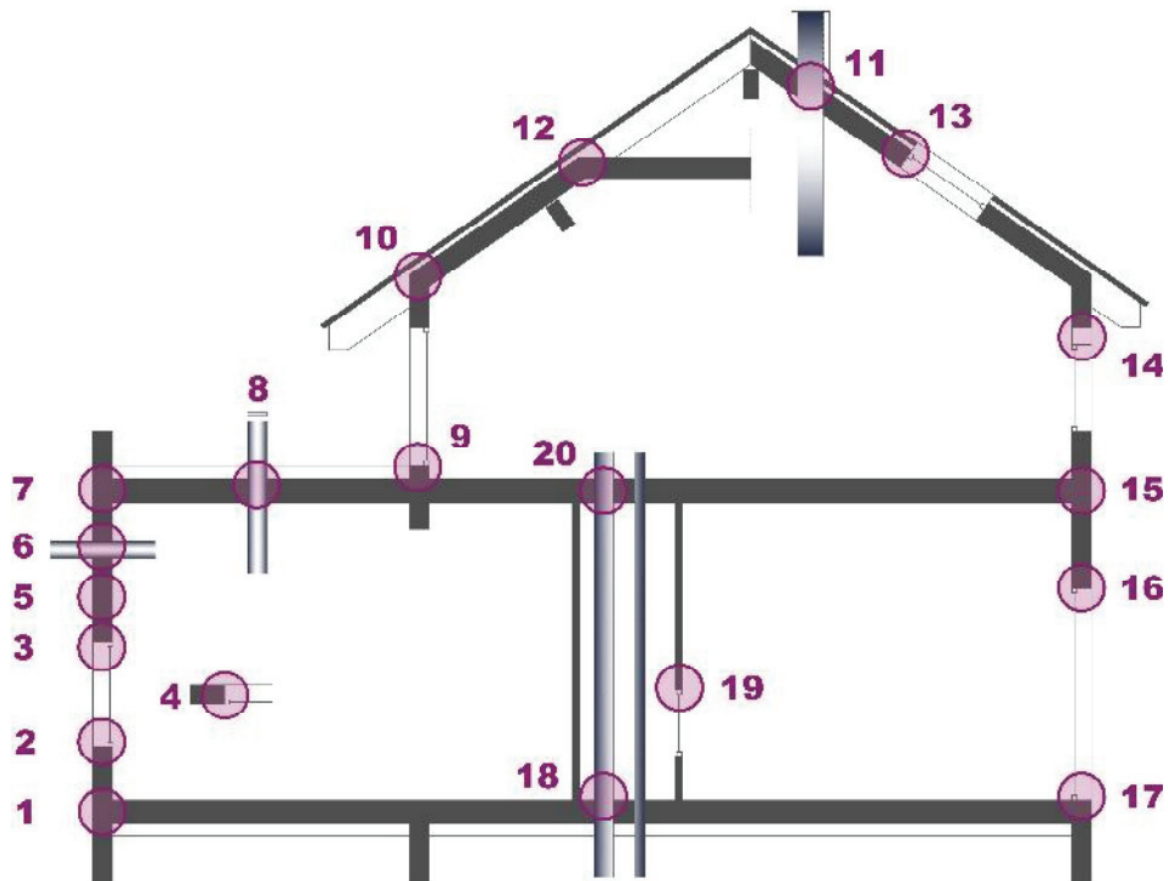

Figure 3.4: Potential leakage points (F.R. Carrie, 2012)

Envelope airtightness must be viewed as a system, which is specified in the design process, designed, detailed, checked and corrected if necessary. In general, the appropriate approach to building airtightness design is divided in 5 steps:

- 🏠 **Design:** First, it is useful to specify the desired building performance. Second, a proper design strategy is necessary, building airtightness must be included already in the early stages of building design, so that an appropriate building envelope, junctions and construction details can be predicted and designed.

- 🏠 **Demonstration:** Contractors should be educated about the proper way of constructing and appropriate usage of suitable products in order to achieve a certain level of building. Therefore, on-field workshops are necessary to train contractors.
- 🏠 **Construction:** In the construction phase, regular control of executed construction works according to detailed drawings and specifications should be carried out.
- 🏠 **Monitoring:** Airtightness measurements and regular preparation of the Blower door final report. Normally, preliminary Blower door test is necessary in order to identify and correct the flaws in construction details.
- 🏠 **Evaluation:** Corrections in case of detected deviations from the design (only if necessary) and removal of detected flaws. A final airtightness test needs to be carried out after all corrections are done.

Advantages and disadvantages

The main advantages of building airtightness are:

- 🏠 Lower energy consumption and heating costs
- 🏠 Improved building comfort
- 🏠 Improved energy efficiency for mechanical ventilation with heat recovery
- 🏠 Improved whole building energy-efficiency
- 🏠 Reduced moisture infiltration levels

When buildings are constructed with airtightness and energy-efficiency in mind, it can lead to unintentional problems due to inappropriately designed or constructed details, alongside with unsuitable mechanical ventilation. Consequently, next problems may occur:

- 🏠 Condensation on exterior walls and windows
- 🏠 Poor indoor air quality
- 🏠 Excessive indoor humidity
- 🏠 Stuffy air
- 🏠 Development of mould

Energy performance

With the appropriately designed and executed building airtightness, the building energy demand can be significantly reduced.

The analysis of energy savings due various airtightness levels in multi-family buildings showed that energy for heating can be reduced for approximately 40 % and cooling for approximately 20 %, as better airtightness directly reduces uncontrolled heat losses and enable effective performance of mechanical ventilation systems (Jačimović, 2018).

Financial data: investment, operation and maintenance

- 🏠 Construction (*delivery and installation*):
Construction costs are connected with the desired airtightness level. Namely, surplus costs for certain airtightness level depend on sealing materials quality and techniques, preparation and on-site training for blower door test, blower door test and internal control, all in the frame of imposing “the airtightness quality assurance protocol” in construction.

- 🏠 Maintenance:
 - 🏠 Besides window seals, which need to be checked/changed approximately every 10 years, there are not any additional maintenance costs.

- 🏠 Operation:
 - 🏠 There are no operation costs.

Environmental issues

Ensuring building airtightness has no special environmental issues.

Development potential

As mentioned in energy performance section, increasing airtightness has high energy saving potential. In recent years, improving building envelope, especially adding thermal insulation and more layered windows, has become a common practice. However, with these measures, one can only reach a certain level of energy savings, thus increasing airtightness represents a great potential for energy savings and reaching NZEB.

References

- [1] F.R. Carrie, R. J. (2012). *Methods and techniques for airtight buildings*. Sint-Stevens-Woluwe: Air Infiltration and Ventilation Centre.

- [2] Jačimović, M. (2018). *Optimisation of nearly zero-energy building with tool for non-stationary thermal analysis*. Ljubljana: Faculty of Civil Engineering, University of Ljubljana.

3.2. Technical building systems

Technical building systems are divided into five groups: Ventilation, Domestic hot water, Heat generation, Heating emission, and Cooling.

Ventilation

3.2.1. Hygro-sensible ventilation

Hygro-sensible ventilation is a system of controlled forced ventilation for multi-dwelling buildings. The flow of forced ventilation is regulated by materials that react to the relative humidity: when the rooms are empty, the flow is minimal (0.2 exchanges per hour) when people are in the premises, the flow increases to the optimum (0.5 to 0.8 exchange per hour). The air comes to the living space through special rosettes with a hygroscopic tape. The used air leaves the living space through the slots in or under the door and continues the way to the sanitary facilities and the kitchen, where the fans blow it out.

Hygro-sensible ventilation do not have the heat recovery, but it still controls the air exchange rate. Therefore, in comparison with mechanical ventilation with heat recovery the energy savings are lower than in case with the hygro-sensible ventilation.

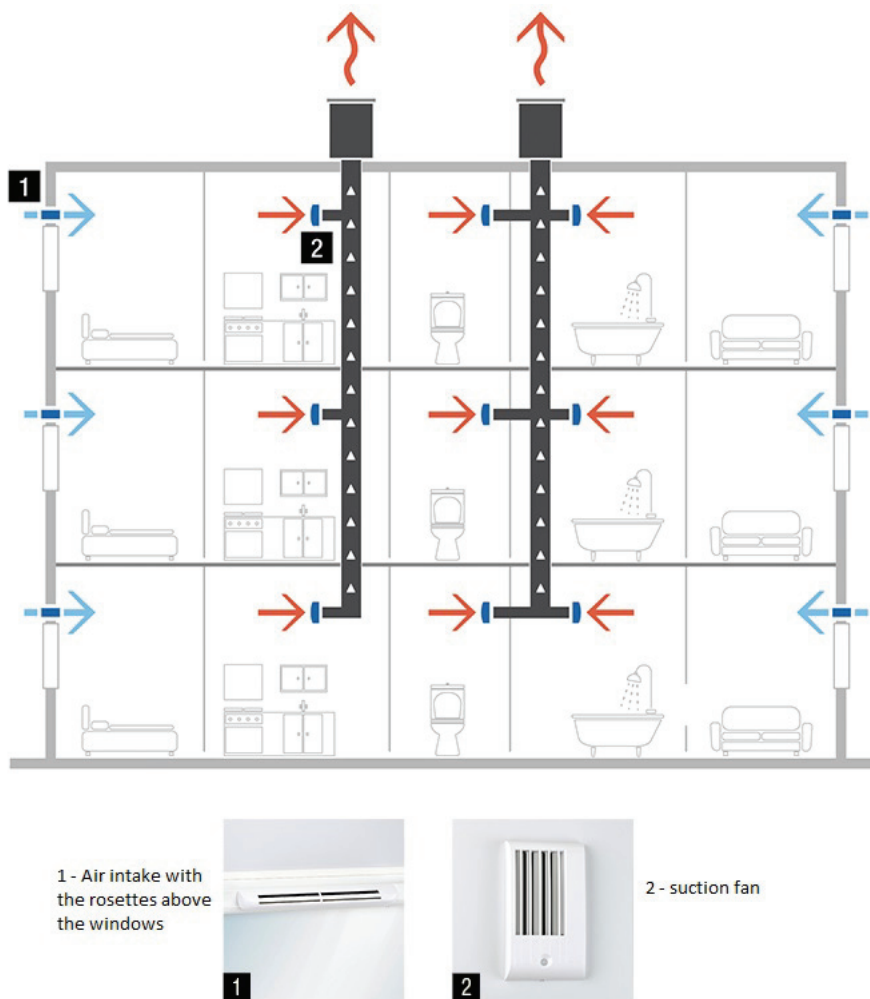

Figure 3.5: Hygro-sensible ventilation scheme (Ventilation systems, 2018).

A typical hygro-sensible ventilation system consists of air intake with the rosettes above the windows, the suction fan and exhaust ducts (see Figure 3.5).

Advantages and disadvantages

The main advantages of hygro-sensible ventilation are:

- ⊠ Low investment costs; e.g., the mechanical ventilation with heat recovery is approximately three times more expensive than hygro-sensible ventilation system, because of more complex equipment, pipes and ducts.
- ⊠ Low labour costs for installation due to relatively simple system.
- ⊠ Improving air quality by regulating moisture.

The main disadvantages of hygro-sensible ventilation are:

- 🏠 The probable disadvantage of hygro-sensible ventilation is that it is harder to achieve NZEB characteristics due to higher ventilation losses, since from a certain level of building's envelope insulation, the energy efficiency very much depends on heat recovery
- 🏠 the end-users may find the controlled ventilation disturbing due to the noise of fans or that they continue with the traditional use of (excessive natural) ventilation of flats (leave the by windows open) and this compromise the expected energy performance of the building.

Energy performance

This system does not include heat recovery, which is not such a big disadvantage, since the system accurately defines flows and therefore the energy losses are minimized. The main advantage is the quality of living in so ventilated buildings due to the constant controlled and fresh airflow, which prevents excessive water vapour condensation and mould growth (Jerman, 2009).

Financial data: investment, operation and maintenance

- 🏠 Construction (*delivery and installation*):
 - 🏠 System investment and labour cost [€/yrpartment]: 1500 EUR
 - 🏠 Installation time [h/yrpartment]: 8 h.
- 🏠 Maintenance:
 - 🏠 Experiences show that not much maintenance is needed for hygro-sensible ventilation, no adjustments are needed, only simple annual dusting. The hygro-sensible rosettes operate independently.
- 🏠 Operation:
 - 🏠 No special requirements are necessary for operation. Operational costs for this type of ventilation are quite low, approximately from 0.3 to 0.5 EUR/month per apartment (Jerman, 2009).

Environmental issues

The hygro-sensible ventilation system parts are typically made from polystyrene and Acrylonitrile butadiene styrene.

Development potential

Development of hygro-sensible ventilation can be connected with the fact that not all apartment users are in favour of using mechanical ventilation with heat recovery, due to various reasons, like higher operational costs and complex control of mechanical ventilation. Hygro-sensible ventilation can be considered as a passive system that provides good ventilation with low investment and maintenance costs and as well simple maintenance.

Besides, it is not to be expected that in the near future, mechanical ventilation will be mandatory in all new built buildings, therefore hygro-sensible ventilation present a solution that enables reaching NZEB level, if other parameters of building envelope and systems are designed properly.

References

- [1] Ventilation systems. (2018). Retrieved from AERECO:
<https://www.aereco.co.uk/technology/ventilation-systems/>
- [2] Jerman, B. (2009). Higrosenzibilno prezračevanje. Retrieved from E-NETSI:
<http://www.e-netsi.si/si/prezracevanje/higrosenzibilno-prezracevanje.html>

3.2.2. Decentral, hybrid ventilation with heat recovery

Decentral ventilation is full individual ventilation systems in each flat with inlet and outlet through the facade and heat recovery inside the flat. A decentral ventilation system in combination with a hybrid solution, where the mechanical ventilation are stopped during summer result in lower electricity consumption. The lower electricity consumption comes partly from the short ducts and partly from the summer stop. Additionally, it is possible to make the ventilation more efficient and better fitted to the individual flat.



Figure 3.6: Decentral ventilation unit inside a cupboard in a flat.

During winter, the systems are controlled individually by the moisture content in each flat, though with a minimum airflow to ensure adequate indoor climate. In Denmark, the minimum required airflow is fixed at 0.3 l/s per m² floor space equal to approx. 0.5 air changes per hour. During summer, natural ventilation is used and the mechanical system is turned off, but though turned on by PIR sensors in the bathroom and if the cooker hood (integrated part of the ventilation system) is turned on.

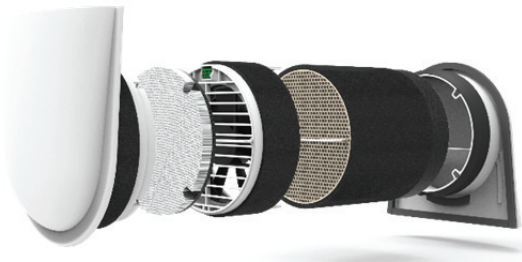

Figure 3.7: MovAir ventilation unit with thermal mass based heat recovery and pulsing airflow.

A less duct consuming solution is the MovAir [1] system, which is based on pulsing supply and exhaust in each room and a capacity heat recovery unit. The supplier promises 91 % heat recovery efficiency at an air flowrate that comply with the Danish Building regulation requirements. The system is a double system with an inlet/outlet and an outlet/inlet unit. The airflow changes direction every 70 seconds and heat is recovered from a thermal mass located in each of the units.

Advantages and disadvantages

+	-
<ul style="list-style-type: none"> 🏠 This solution requires less space for vertical ducts, hence leaving more space that is habitable for the same gross floor area. 🏠 The solution takes up no area on the roof, which e.g. can then be used for harvesting renewable energy. 🏠 No risk of transferring smell from one flat to another as the different ventilation systems are disconnected. 🏠 Less consumption of electricity for air movements due to shorter ducts and summer cut-stop of the mechanical ventilation. 	<ul style="list-style-type: none"> 🏠 Location of the heat recovery unit inside the different flats, entail increased disturbance of the residents for maintenance or leaves maintenance to the residents themselves. 🏠 Placement of fans inside the flats requires extra consciousness in the design to avoid noise nuisance for the residents. 🏠 Inlets, outlets, and windows in the building needs to be located with care to avoid transfer of odours form one flat to another.

Energy performance

The heat recovery unit can have quite high efficiencies and 91 % should be a realistic number. Due to the short ducts, the specific fan power consumption can be kept low, and typical values are found below 1000 J/m³ outside air.

Financial data

Decentral ventilation is cheap compared to central systems due to the reduced ductwork. However, the number of fans increases followed by increased cost. Additionally, maintenance is more complicated and costly compared to a central system.

References

- [1] MovAir: <http://www.movair.dk/forside-nyhed/103-nyt-movair-produkt-der-vil-revolutionere-markedet-for-decentral-boligventilation.html>

3.2.3. Heat pumps in connection to mechanical exhaust ventilation systems or balanced ventilation systems with heat recovery

An exhaust air heat pump is ultimately an air-to-water or air-to-air heat pump. The only significant difference is that not the outside air is used as heat source, but the exhaust air from an installed central ventilation system. An exhaust air heat pump can be installed in a central exhaust ventilation system (like for example in the German solution set DE-SS8) as well as in a central balanced ventilation system with (like in DE-SS2) or without heat recovery.

The exhaust air is extracted from the apartments (mostly the bathrooms, sometimes also the kitchens) via a central ventilation system and then delivered to the exhaust air heat pump. The heat source heat exchanger (evaporator) is installed in the main exhaust air duct downstream of the exhaust fan. The evaporator transfers the heat from the exhaust air to the refrigerant of the exhaust air heat pump, which then evaporates. An electricity driven compressor compresses the refrigerant vapour. Due to the now increased pressure of the refrigerant vapour, it condenses at a significantly higher temperature level at the condenser of the heat sink. The condenser can be connected to different consumers like domestic hot water storages (see Figure 3.8 and DE-SS8), heating storages (both air-to-water) or even the supply air of a balanced ventilation system (air-to-air).

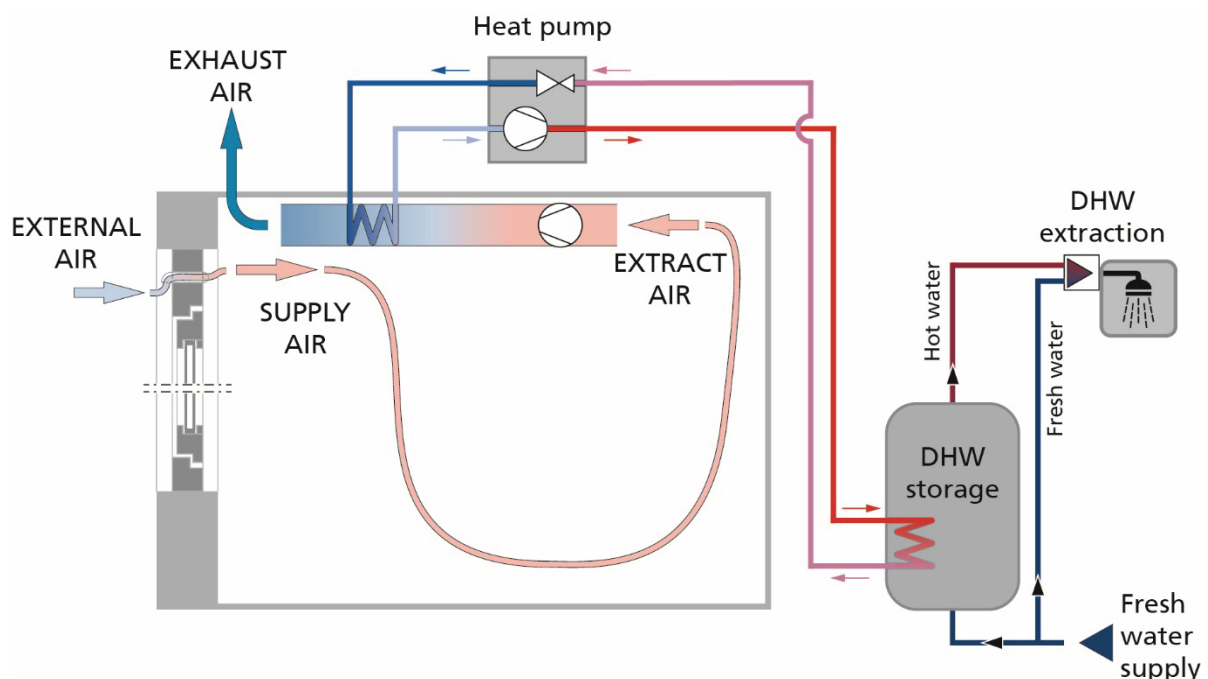

Figure 3.8: Exhaust air heat pump connected to the domestic hot water storage.

If an exhaust air heat pump is connected to a balanced ventilation system with heat recovery, the evaporator is located after the heat recovery unit (see Figure 3.9). After the

exhaust air has flowed through the evaporator of the exhaust air heat pump, it is emitted to the outside.

In addition to the two systems described above, the exhaust air heat pump can also be used in balanced ventilation systems without heat recovery. There are also system configurations possible that add outdoor air stream to the exhaust air and therefore increase the energy potential of the heat pump. This is often used in case of balanced ventilation systems with heat recovery where the exhaust air is already at a very low temperature level.

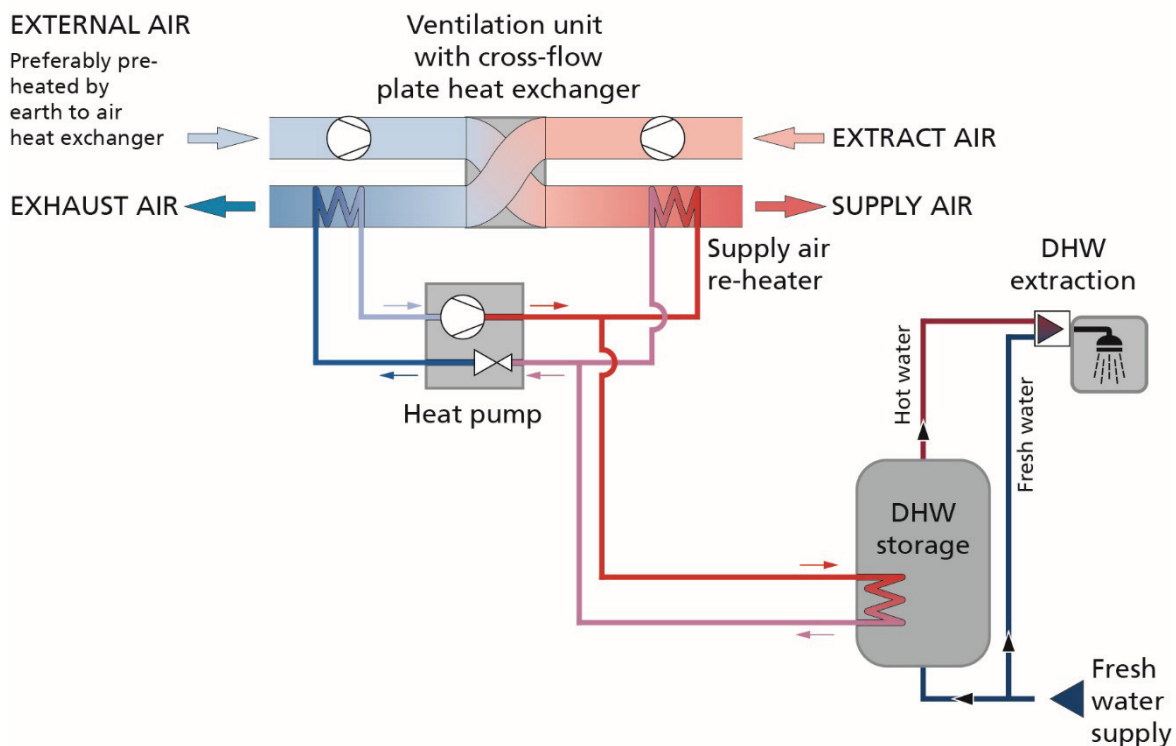

Figure 3.9: Exhaust air heat pump in a balanced ventilation system with heat recovery.

Advantages and disadvantages

+	-
<ul style="list-style-type: none"> ⊠ Due to the high temperature level of the exhaust air throughout the year, exhaust air heat pumps are very suitable for domestic hot water preparation. ⊠ The advantage of a heat pump in combination with an exhaust air ventilation system in comparison to a combination with a balanced ventilation system is the much lower costs for the 	<ul style="list-style-type: none"> ⊠ The quantity of exhaust air is limited. Therefore if the exhaust air heat pump is used for heating, in most cases a second heat generator is necessary. If the exhaust air heat pump just delivers DHW its thermal output is most likely sufficient without an additional heat generator. ⊠ In any case, exhaust air heat pumps can

ventilation system.	only take over a significant share of the heating if the heated building has a high insulation standard (like NZEBs). ☞ If exhaust air heat pumps are used for DHW generation the ventilation system has to run the whole year or a second DHW generator has replace the heat pump in summer.
---------------------	--

Energy performance

According to the calculations performed for the typical German building the exhaust air heat pump has an annual COP of 3.26 for heating (7,595 kWh/yr or 7.71 kWh/(m²_{NFA}yr) of recovered heat from the exhaust air at an electricity input of 3,352 kWh/yr or 3.40 kWh/(m²_{NFA}yr) in the solution set DE-SS8. The annual COP for the pure domestic hot water production in solution set DE-SS8 is 3.3 (16,615 kWh/yr or 16.87 kWh/(m²_{NFA}yr) of recovered heat from the exhaust air at an electricity input of 6,923 kWh/yr or 7.03 kWh/(m²_{NFA}yr)).

Financial data: investment

The financial data below includes only costs for the heat pump, not for the required ventilation system.

☞ Construction (delivery and installation): The construction costs for the exhaust air heat pump are calculated with 1,337 €/kW of thermal output.

☞

Environmental issues

Following the ban on ozone-depleting refrigerants, new heat pumps mainly use hydrofluorocarbons (HFCs) and hydrohalogenated hydrofluorocarbons (HFCs) such as R-407C, R-410A, R-417A and R 507A. These do not damage the ozone layer but are climate-active and contribute to the greenhouse gas effect and are thus listed as hazardous to the environment in the Kyoto Protocol. For environmental reasons, heat pump manufacturers try to reduce the amount of refrigerant or use natural refrigerants such as ammonia (R-717), hydrocarbons (R-600a, R-290) or carbon dioxide CO₂ (R-744).

Development potential

According to a study (Born, 2017) the COP-value (based on EN 255 - A2/W35) of air-to-water heat pumps increases since 1993 with 0,059 per year. According to the same study the annual COP of air-to-water heat pumps increased from 3.1 in 2013 to 3.3 in 2016, indicating the further development potential.

References

- 🏠 Born, H.; Schimpf-Willenbrink, S.; Lange, H.; Bussmann, G.; Bracke, R.: Analyse des deutschen Wärmepumpenmarktes - Bestandsaufnahme und Trends. [Analysis of the German heat pump market - stocktaking and trends]. Zentrum für Sonnenenergie- und Wasserstoff-Forschung Baden-Württemberg (ZSW). 2017.

Domestic hot water

3.2.4. Energy efficient taps

The energy consumption for heating domestic hot water is part of the building's total energy needs. Savings can be achieved by limiting the amount of hot water and by tapping water at a lower temperature.



Figure 3.10: Principle for water saving mixer fixtures.

The savings are achieved by adjusting the tap to the daily needs of a normal household. By actively operating the tap, the amount of water or temperature may increase. When the grip is released, the tap is automatically reset for daily operation.

The setting of the tap can be adjusted to meet the daily needs of an individual household.

Advantage and disadvantages

The advantages of the energy efficient taps are their simplicity in use and therefore an easy and quick operation in the daily household. Besides - obviously:

- 🏠 Water savings
- 🏠 Energy savings

The disadvantage is that it requires active operation during forced operation.

Energy performance

The EU has developed an energy labelling system for water taps corresponding to the labelling system for household appliances. The labelling system can help buyers, installers and consumers to choose the most energy efficient products. The labelling system has shown energy savings of up to 40 percent compared to traditional water taps.

In Denmark, energy-saving water taps are tested in Energy FlexHouse at Danish Technological institute. Here a regular Danish family consisting of two adults and their children has tested the water taps in practice during three months, and 25 % savings were measured on the hot water and 21 % on the total water consumption compared to ordinary water taps.

Environmental issues

Energy-saving water taps have a positive impact on the environment in terms of a reduced consumption of water and energy.

The environmental impact of the energy-savings water taps in terms of material and production is not known but is considered not to be an issue. Typically, other factors are important, such as type of materials and design.

Development potential

Water-saving taps are generally used as a standard in Denmark, where the amount of water is limited by various elements such as showerheads with optimal dispersion and aerator that spread and mix air into the water.

Energy savings taps with temperature limitation are under development and it is estimated that a mandatory label system will further increase the spread.

A further development can be expected that increases the regulation of quantity and temperature to an even greater extent, thus minimizing water waste and energy.

References

- [1] "Test af vandbesparende bledningsbatterier i EnergyFlexHouse [In Danish: Test of water saving fixtures in EnergyFlexHouse]". Danish Technological Institute, May 2011.

3.2.5. Heat recovery from grey waste water

Heat recovery from grey wastewater (in residential buildings shower water) is especially efficient in buildings with numerous drains, e.g. swimming pools, sports facilities, apartments blocks, hotels, hospitals, nursing homes, etc.

The combined wastewater from the showers in a building flows through double pipes in the heat exchanger and in this way fresh supply water is pre-heated by heat exchange with the hot wastewater. The highest efficiency is achieved when both the fresh water to the showers and the fresh water to the auxiliary heater is pre-heated. If continuous use of showers cannot be ensured, e.g. in small apartment blocks, a storage tank can be included in the system. The efficiency is approx. 60 % of the energy content in the wastewater. System efficiency is typically between 30 and 60 %. This will normally result in a payback period of 3 - 6 years.

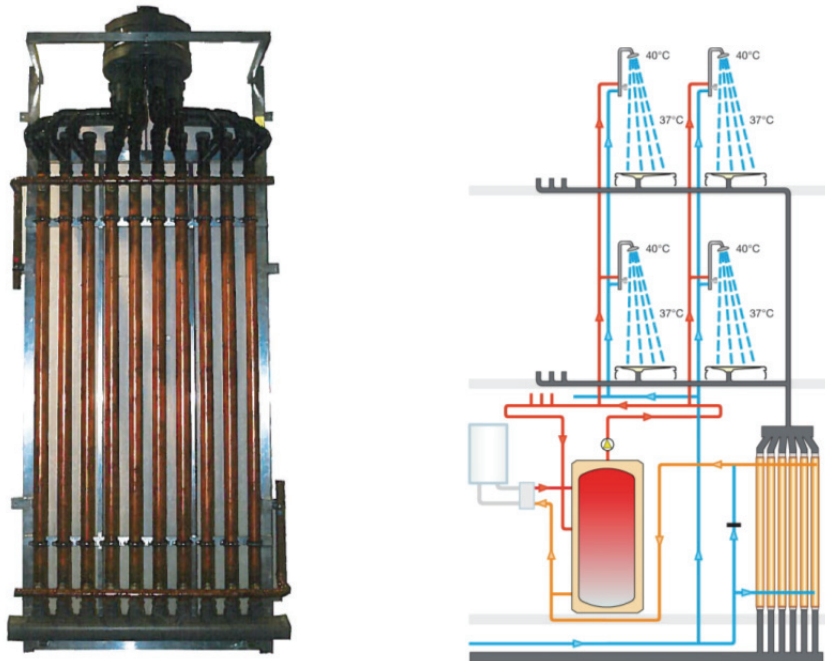

Figure 3.11: Recoh® multi-vert heat exchanger (Q Blue 2018).

A typical heat exchanger consists of 4, 6 or 8 parallel joined tubular heat exchangers (but many other configurations are commercially available) and the wastewater is distributed via a manifold to the tubes where gravity ensures the downward flow. The fresh supply water flows upwards simultaneously by normal pressure differences and is being pre-heated at the same time.

There is also the possibility to install decentral grey wastewater heat recovery systems for each shower or residential unit individually. The heat recovery unit can for example be installed in the storey directly below the shower connected to it. In the heat recovery unit the fresh water is pre-heated through the warm wastewater and flows from there directly to the water tap of the shower, where it is connected to the fresh water connection.

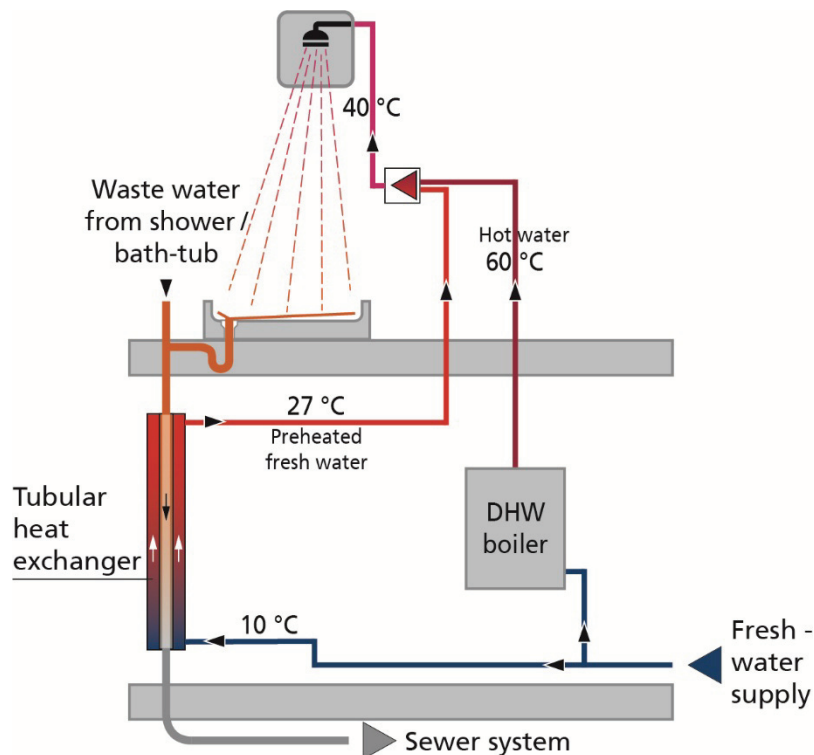

Figure 3.12: Decentral application of grey water heat recovery. © Fraunhofer IBP.

Advantages and disadvantages

+	-
<ul style="list-style-type: none"> 🏠 Continuous usage of domestic hot water to showers will increase the efficiency of the heat exchanger. The system will thus be more efficient in large multi-family buildings compared to smaller ones. 🏠 Due to the high water velocity in a vertical heat exchanger, experiences show that there is little need for maintenance of the heat exchanger. 	<ul style="list-style-type: none"> 🏠 A thermal solar collector may have decreased efficiency used in combination with a central wastewater heat recovery system.

Energy performance

Estimated heat recovery efficiency is between 30 and 60 % of the energy content in the wastewater from the showers.

Financial data: investment, operation and maintenance

- 🏠 Construction (*delivery and installation*):
 - 🏠 Installation time, and thus costs, highly depends on the installation principle, and there are several options (balanced and unbalanced water flow through the heat exchanger) with reduced heat recovery efficiency, up to 15 %-points, as a consequence.
 - 🏠 For decentral usage of the grey water heat exchangers the delivery and installation costs amount to 800 € per residential unit based on the German NZEB solution sets DE-SS2 and DE-SS3.
- 🏠 Operation:
 - 🏠 No special requirements.

Development potential

Development of heat recovery systems for grey wastewater is an increasingly interesting topic since domestic hot water is the only heat demand in NZEB's that can't be reduced by envelope optimization. It is hence only possible to reduce the energy demand for domestic hot water by use of renewable energy sources and/or heat recovery on the wastewater.

There are two different approaches for central heat recovery on wastewater, i.e. vertical systems, as described in this section, or horizontal systems. The vertical systems is especially suited for buildings with a basement while horizontal systems is more suited for buildings without a basement. Among the horizontal systems are unites that are more or less similar with the vertical systems shown while others are integrated in the base of the shower room and provides direct heat recovery while showering, typically in a single family unit. Shower Heat Recovery - Overview of Commercially Available DWHR Systems (Kimmels 2011) offers an overview of these kind of systems commercially available in 2011.

References

- [1] Kimmels, Arthur. 2011. "Shower Heat Recovery Overview of Commercially Available DWHR Systems." www.meanderhr.com.
- [2] Q Blue. 2018. "Weblet Importer." 2018. <https://www.q-blue.nl/en/products/q-blue-multivert-en>.

3.2.6. Domestic hot water heat exchange module

The DHW heat exchange module (sometimes called fresh water station) is a unit that generates domestic hot water with the continuous flow principle. The DHW heat exchange module consists of a high efficient heat exchanger, a charging pump, a control system, a heat supply and return pipe as well as a fresh water input and hot water output pipe. The units have been developed to avoid circulation systems (and their losses) and hygienic requirements to the hot water system. Generally, the DHW in bigger systems such as multi-family houses has to be heated up to 60 °C in order to prevent legionellae. The domestic hot water heat exchange module reduces the volume of DHW in the pipes. Therefore, the requirement for heating up to high temperatures is not applicable for these systems. In most cases DHW heat exchange modules are located in each single residential unit or sometimes on storey level.

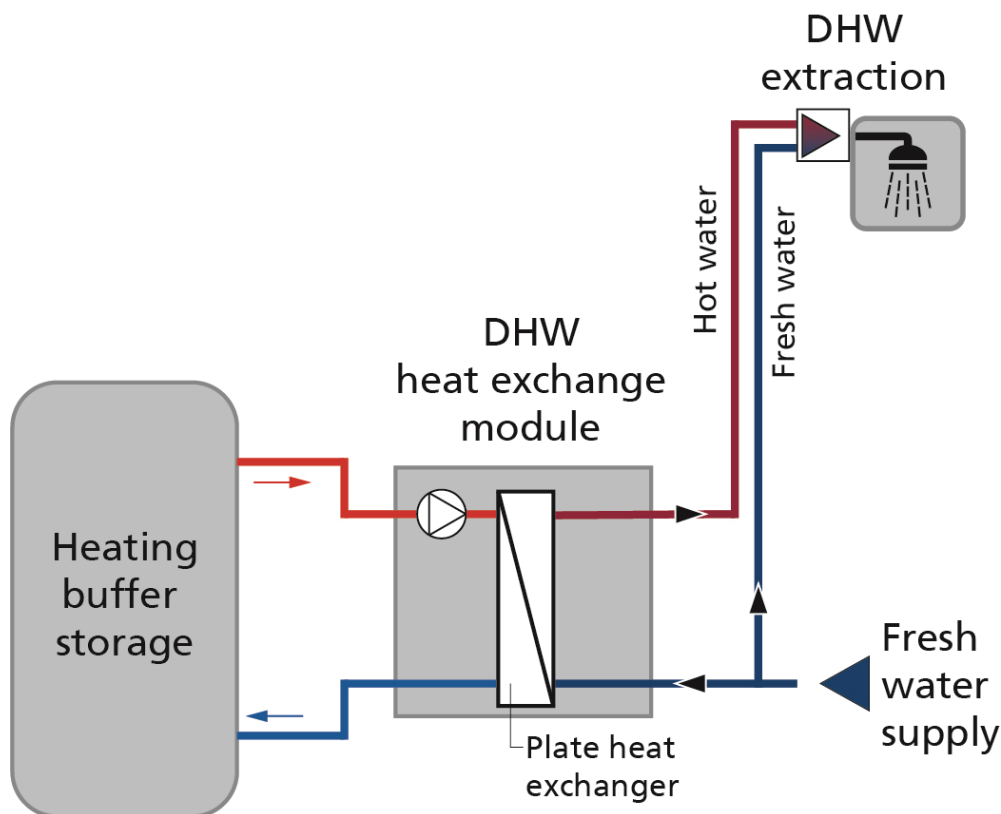

Figure 3.13: Schematic drawing of a DHW heat exchange module connected to a heat source (heating system) and a heat sink (water tap) © Fraunhofer IBP.

The DHW heat exchange module is supplied with heat by the heat generation unit and the corresponding buffer storage (see Figure 3.13). If the control system of the DHW heat exchange module notices DHW tapping it activates the charging pump. Now heating water is pumped through the heat exchanger. Due to the DHW tapping cold fresh water also flows through the heat exchanger due to the supply pressure of the fresh water. The fresh water heats up in the heat exchanger and is then supplied to the tapping point.

Advantages and disadvantages

+	-
<ul style="list-style-type: none"> 🏠 Low temperature heat can be used to generate hygienic domestic hot water. 🏠 The distribution losses of the DHW distribution are minimized due to much shorter pipe lengths. 🏠 No circulation of DHW is necessary. 🏠 No costs for the legionella checks (every third year). 	<ul style="list-style-type: none"> 🏠 Even though the distribution piping is much shorter and the circulation piping is completely missing, the installation costs of the DHW heat exchange modules are higher.

Energy performance

There are two opposing factors influencing the efficiency of the DHW heat exchanger:

1. Lower temperatures of the DHW distribution and shorter distribution pipe lengths lead to lower energy losses.
2. DHW can be required at any time (24/7). The DHW heat exchange module works without storage, therefore the heat generation system (boiler or similar) has to run also 24/7 all year round.

DHW heat exchange modules are used in DE-SS8. However the DHW generation system includes also an exhaust air heat pump and a condensing gas boiler therefore a general energy efficiency of the modules alone can't be given.

Financial data

- 🏠 Construction (delivery and installation): The construction costs of a DHW heat exchange module in Germany (see DE-SS8) can be calculated with 2,400 € per residential unit.

3.3. Generation

3.3.1. Exhaust air heat pump for heating

See section 3.2.3 Heat pumps in connection to mechanical exhaust ventilation systems or balanced ventilation systems with heat recovery.

3.3.2. Exhaust air HP for domestic hot water

See section 3.2.3 Heat pumps in connection to mechanical exhaust ventilation systems or balanced ventilation systems with heat recovery.

3.4. Heating

3.4.1. Electric space heating emitters

Conventional domestic space heating systems use radiators (in which the water warmed up by the heat supply circulates) as emission sub-system to deliver heat to the built environment. This thermal exchange takes place mostly by convection. Infrared heating, instead, is based on the infrared radiation (wavelengths from 2.5 microns on) emitted by a heater and is hitting the objects present in the room (walls, ceiling, floor, furniture, human beings). The absorbed radiation causes the vibration of molecules and, thus, the production of heat. The technology provides comfortable space heating, warming up surfaces instead of the whole air volume present in the room. In addition, the transitory phase at the switching is quicker than that of conventional hydronic systems.

Even though the mechanism of radiation heat transfer is known since centuries, the electric infrared heating gained interest and market penetration only in the past few years, thanks to the maturity of the technology and the thermostatic control, which exploit the potential for energy efficiency. Another crucial issue is the high thermal insulation level in new buildings, which strongly reduces the peak power and the energy use for space heating, and, together with the massive penetration of PV technologies, is creating favourable conditions for electricity as energy source for space heating in many climatic conditions in Europe.

Such panels are available in many sizes, from 200 to 1,500 Watts and more. The choice depends on the power required by the room in which the panel shall be installed. The basic material for infrared heating is carbon graphite, however different finishing solutions can be used, opening the field for interior design and home decor solutions, among them:

- 🏠 Steel
- 🏠 Aluminium
- 🏠 Glass
- 🏠 Marble
- 🏠 Granite and other natural stones

Special prints can also be applied on panels. Such products do not need any centralised system, they are simple plug-and-play solutions to be connected to the home electric plant. The plate can reach a surface temperature of 100 °C, hence care must be taken to avoid

direct contact. Exemplary applications of the technology for residential buildings are reported in the next figure



Figure 3.14: Exemplary applications of special printed and coloured of electric infrared heating panels © Tesi Group Srl (www.celsiuspanel.it)

Advantages and disadvantages

+	-
<ul style="list-style-type: none"> ⊞ No need of piping and distribution systems for space heating, neither for technical rooms dedicated to the heat supply system. ⊞ Very low maintenance costs ⊞ Heating solid objects, they prevent moisture formation on surfaces and inhibit the spread of mould. ⊞ Easy to install and re-install in case of building renovation ⊞ Possibility of high aesthetic quality 	<ul style="list-style-type: none"> ⊞ Costs are higher than for conventional emission components ⊞ Fixed cost of the electricity bill may increase in some countries (e.g. Italy), in case of a higher electricity power supply ⊞ Long term cost might be higher than for conventional solutions, due to the cost of electricity compared to gas or others. ⊞ The use of direct electrical heating might be banned or penalised (e.g. RES can't be accounted for it in the energy performance certificate) in some countries.

Energy performance

The efficiency of the direct electrical heating system is 100 %, there are no losses. However the primary energy factor of the energy source electricity is higher than that of other energy sources like gas, etc.

Financial data: investment, operation and maintenance

🏠 Construction (delivery and installation):

Very cost effective plug and play solutions. The panels are thin and easy to handle. Many products are available on the market, with very high cost deviations, depending on several parameters, especially those related to aesthetics.

- 🏠 In the Italian solution sets ITR-SS3 and ITT-SS5 the cost for the electrical heaters was determined to 0.8 €/W
- 🏠 In the German solution set DE-SS2 the cost for the electrical heaters was determined to 0.45 €/W.

Development potential

The technology is mature and well present on the market. Margins for efficiency can be found in more efficient control systems.

References

- 🏠 www.redwell.com
- 🏠 www.fenixgroup.eu
- 🏠 www.celsiuspanel.it

3.4.2. Cooling and overheating risks in NZEB multifamily houses

NZEBs are characterised by higher insulation levels and being more air-tight compared to conventional buildings, conditions that may create ground for overheating risk and need for the installation of active cooling systems. Risks in central and northern Europe residential buildings are still limited, but in southern Europe, such risks increase; moreover, global warming and intensification of urban heat island may raise the risk in the entire continent in the next decades.

Even if the increase of the indoor temperature in well-insulated buildings during summer is well documented, the problem can properly tackled with the contribution of two main actors:

- 🏠 Designers and planners. Professionals in charge of identifying solutions able to exploit the potential of passive cooling and overheating prevention. As examples, issues may include building apertures' sizes and layout to create favourable conditions for

cooling by ventilation (especially at night); solar shading systems correctly selected according to the facade orientation; finishing layers with high reflectance, especially for roofs.

- 🏠 Building users. Differently from commercial buildings, where several of the above functions can be carried out in automated regime, the user's behaviour is crucial in dwellings, since he has to proactively and properly manage the building features to maximise the indoor comfort (opening and closing of windows, activation of solar shading, etc.).

As an example, it can be cited the Italian typical NZEB used for CoNZEBs project, which has dwellings with theoretical cooling demand in the 12-20 kWh/(m²yr) (according to the national calculation method). However, this building has no active cooling system installed, being not mandatory according to the national building code. The overheating risk was then analysed through detailed thermal simulation in transient regime. It was found out that using shading devices with 0.8 shading coefficient and assuring 1.5 ACH at night (absolutely realistic requirements), it is possible to reduce the discomfort hours to less than 100, thus complying with the requirements defined in EN 15251:2007: Indoor environmental input parameters for design and assessment of energy performance of buildings addressing indoor air quality, thermal environment, lighting and acoustics.

According to these results, achieved for the most critical country, the absence of active cooling systems in the CoNZEBs buildings is thus fully reasonably.

Finally, it has also to be mentioned the need of identifying a proper metric to effectively address the cooling/overheating issue in NZEB multi-family houses, actually running along the parallel tracks of an energy performance based approach and an adaptive thermal comfort method in EU standards.

4. Abbreviations / Definitions

AN	‘Gebäudenutzfläche’ is a type of artificial floor area used in Germany for relating the calculated energy use of residential buildings
DHW	Domestic Hot Water
EP	Energy performance
EPC	Energy Performance Certificate
EPS	Expanded polystyrene insulation
GFA	Heated Gross Floor Area
kWp	Kilowatt-peak
MVHR	Mechanical ventilation with heat recovery
MS	European Union Member States
NFA	Heated Net Floor Area
NZEB	Nearly Zero Energy Buildings
PV	Photovoltaic
RES	Renewable Energy Sources
XPS	Extruded Polystyrene insulation

Conditioned floor area	Area of a building that is heated and/or cooled
Living area	Net floor area, including internal walls
Net floor area	Habitable area, i.e. heated net floor area excluding internal walls

5. Annex I – Solution sets

In the following sub-sections, overview tables of the solution sets used in the four countries are shown.

5.1. Denmark

Overview of technologies in solution sets

Technologies		DK typical NZEB (base case)	DK - SS1	DK-SS2	DK-SS3	DK-SS4	DK-SS5
Main feature(s) of solution set			More efficient insulation material in external walls;	DHW solar heating, reduced insulation in walls, roof and floor.	4 layer windows, natural ventilation heat recovery on grey wastewater.	Reduced insulation in walls, roof and floor, Decentral mechanical ventilation, energy efficient taps.	PV panels, reduced insulation in walls, roof and floor; Decentral mechanical ventilation.
Building envelope	External Walls	Description	Better lambda value of insulation material (ETICS). $\lambda = 0,02 \text{ W}/(\text{mK})$	Insulation thickness reduction: -50 mm	Id.	Insulation thickness reduction: -50 mm	Insulation thickness reduction: -50 mm
		U-value [$\text{W}/(\text{m}^2\text{K})$]	Id.	0.22	Id.	0.22	0.22
Building envelope	Fenestration, incl. glazing, frame, spacer etc.	Description	Id.	Id.	4-layer glazed windows	Id.	Id.
		U-value [$\text{W}/(\text{m}^2\text{K})$]	0.15	Id.	Id.	0.6	Id.
Building envelope	Roof	Average g-value (solar energy transmittance)	0.85	Id.	Id.	0.40	Id.
		Description	0.53	Id.	Insulation thickness reduction: -100 mm	Id.	Insulation thickness reduction: -100 mm
Building envelope	Cellar ceiling/ground slab	U-value [$\text{W}/(\text{m}^2\text{K})$]	0.1	Id.	0.14	Id.	0.14
		Description	Slab on ground	Id.	Insulation thickness reduction: -100 mm	Id.	Insulation thickness reduction: -100 mm
Building envelope	Thermal bridges	U-value [$\text{W}/(\text{m}^2\text{K})$]	0.1	Id.	0.14	Id.	0.14
		Description	1) Around windows 2) Foundations	Id.	Id.	Id.	Id.

Technologies		DK typical NZEB	DK - SS1	DK-SS2	DK-SS3	DK-SS4	DK-SS5
Building envelope ¹⁶	Line losses [W/(mK)] / ΔU value [W/(m²K)]	1) 0.03 2) 0.20	Id.	Id.	Id.	Id.	Id.
	Average U-value [W/(m²K)], (incl. windows) Dimensioning heat loss per m² gross floor / National comparison value. (incl. windows) [W/m²]	0.26 8.5 / 13.7	Id.	9.8 / 13.7	0.21 7 / 13.7	0.31 9.8 / 13.7	0.31 9.8 / 13.7
Airtightness	Description	National LE standard	Id.	Id.	Id.	Id.	Id.
Technical Building Services (TBS) systems	Air-flow [l/sm²]	1 l/m² per sec. at 50 Pa.	Id.	Id.	Id.	Id.	Id.
	Air-change [h ⁻¹]		Id.	Id.	Id.	Id.	Id.
	Generation	Connection to the district heating network (90/70°C). Efficiency:100 %	Id.	Id.	Id.	Id.	Id.
Distribution		Insulated distribution pipes and heat exchanger to national standard.	Id.	Id.	Id.	Id.	Id.
	Emission	Radiators in general but floor heating in bathrooms.	Id.	Id.	Id.	Id.	Id.

¹⁶ The average U-value should be calculated according to EN ISO 52018-1:2017 per m² thermal envelope, including thermal bridges.

Technologies		DK typical NZEB	DK - SS1	DK-SS2	DK-SS3	DK-SS4	DK-SS5
DHW	Generation	Heating through district heating heat exchanger. Efficiency: 100 %	Id.	Id.	Id.	Id.	Id.
	Distribution	Insulated pipes and circulation using a 24/7 low-energy pump	Id.	Id.	Id.	Id.	Id.
	Emission	Standard fixtures and shower	Id.	Id.	Heat recovery waste water system with heat water reduction of 50 %	Efficient energy water taps with a reduction of 25 %.	
Ventilation	Description	Balanced mechanical ventilation (0.34 l/m ² s) with heat recovery (90 % dry efficiency and SPF 1.2)	Id.	Id.	Window opening and mechanical exhaust ventilation (0.3 l/m ² s) system	Decentral mechanical ventilation (0.34 l/m ² s) with heat recovery (85 % dry efficiency and SPF1.0)	Decentral mechanical ventilation (0.34 l/m ² s) with heat recovery (85 % dry efficiency and SPF1.0)
Cooling	Generation	None	Id.	Id.	Id.	Id.	Id.
	Distribution	None	Id.	Id.	Id.	Id.	Id.
	Emission	None	Id.	Id.	Id.	Id.	Id.
Lighting	Description	Not part of EP calculations, but heat load is included as a standard value.	Id.	Id.	Id.	Id.	Id.

Technologies		DK typical NZEB	DK - SS1	DK-SS2	DK-SS3	DK-SS4	DK-SS5
RES	Solar thermal	None	Id.	Central solar heating system of 9.6 m ² total collector area. Heating production: 3.2 kWh/m ² gross heated area.	Id.	Id.	Id.
	PV	None	Id.	Id.	Id.	Id.	16.8 m ² of mono-crystalline solar panel area. Electricity production: 1.43 kWh/m ² gross heated area.
	Biomass	None	Id.	Id.	Id.	Id.	Id.
	Wind turbine	None	Id.	Id.	Id.	Id.	Id.
	Ambient energy	None	Id.	Id.	Id.	Id.	Id.

Technologies		DK - SS1	DK-SS2	DK-SS3	DK-SS4	DK-SS5
	pumps, etc.)					

Calculated energy and cost values, Denmark

Characteristic values		Typical NZEB (base case)	DK - SS1	DK-SS2	DK-SS3	DK-SS4	DK-SS5
All values are based on the heated <u>gross floor area</u>							
Net energy ¹⁷	Heating	kWh/(m ² yr)	Id.	DHW solar heating, reduced insulation in walls, roof and floor.	4 layer windows, natural ventilation heat recovery on grey wastewater.	Reduced wall, roof and floor insulation, decentral mechanical ventilation, energy efficient taps.	PV panels, reduced insulation in walls, roof and floor; decentral mechanical ventilation.
	DHW	kWh/(m ² yr)	Id.				
	Cooling	kWh/(m ² yr)	Id.				
	(Lighting*)	kWh/(m ² yr)	Id.				
	Total	kWh/(m²yr)	17.4	Id.	19,6	19.5	16.9

¹⁷ **Net Energy** consumption is energy delivered inside the building, without distribution losses and without PEF, without renewable energy systems contribution.

Characteristic values		Typical NZEB	DK - SS1	DK-SS2	DK-SS3	DK-SS4	DK-SS5	
Final energy ¹⁸	Heating (incl. auxiliary energy)	kWh/(m ² yr)	Id.	10.4	17.1	11.3	11.3	
	DHW (incl. aux. energy and RES)	kWh/(m ² yr)	Id.	16	12.4	15.6	18.9	
	Cooling (incl. aux. energy)	kWh/(m ² yr)	Id.	-	-	-	-	
	Ventilation+ Pumps	kWh/(m ² yr)	Id.	1.8	0.5	1.6	1.6	
	(Lighting ¹⁹)	kWh/(m ² yr)	Id.	-	-	-	-	
	(Household electricity ¹⁵)	kWh/(m ² yr)	30.7	30.7	30.7	30.7	30.7	
	Locally produced electricity (PV)	kWh/(m ² yr)	-	-	-	-	1.43	
	Maximum electricity incl. BR18	kWh/(m ² yr)	-	-	-	-	13.15	
	Total EPBD	kWh/(m²yr)	29	Id.	28.2	30	28.5	30.4
	Total (incl. other energy uses)	kWh/(m²yr)	59.7	Id.	58.9	60.7	59.2	61.1
Primary energy ²⁰	District heating	kWh/(m ² yr)	Id.	22.4	25.1	22.9	25.7	
	Gas	kWh/(m ² yr)	Id.	-	-	-	-	
	Electricity (EPBD)	kWh/(m ² yr)	Id.	3.4	0.9	3.1	0.3	
	Electricity (other)	kWh/(m ² yr)	Id.	58.3	58.3	58.3	58.3	
	Total EPBD ²¹	kWh/(m²yr)	26.3	Id.	25.9	25.9	26.0	
	Total (incl. other energy uses)	kWh/(m²yr)	84.6	Id.	84.2	84.2	84.3	
	District heating	€/m ² yr	2.37	Id.	2.29	2.56	2.62	
	Gas	€/m ² yr	-	Id.	-	-	-	
	Electricity (EPBD) ⁵	€/m ² yr	0.47	Id.	0.53	0.14	0.07	
	Electricity (other)	€/m ² yr	9	Id.	9	9	9	
Total (incl. other energy uses)	€/m²yr	11.8	Id.	11.8	11.7	11.7		

¹⁸ **Final energy** consumption is the total energy consumed by end users. Thus, the energy that reaches the final consumer's energy meter and excludes energy used by the energy sector itself, i.e. without PEF, inclusive renewable energy systems contribution

¹⁹ Not part of the building energy performance calculation in any of the 4 countries, but used to calculate the possible energy cost savings due to PV

²⁰ **Primary Energy** Factors describes the efficiency of converting energy from primary sources (like fossil fuels...) to secondary energy carriers (e.g. electricity) that provides the services delivered to the end user to heat, cool, ventilate etc. the building (EN ISO 52000-1).

²¹ Final energy demand included in the national EPBD calculations.

Characteristic values		Typical NZEB	DK - SS1	DK-SS2	DK-SS3	DK-SS4	DK-SS5
Investment costs	Building envelope components	€/m ²	-2,1	-9,3	+40,7	-9,3	-9,3
	Service systems	€/m ²	±0	+3,8	-58,8	-5,7	-3
	Total	€/m²	-2,1	-5,5	-18,1	-15,0	-12,6
Maintenance costs	Building envelope components	% of investment costs	±0 %	±0 %	+2 %	±0 %	±0 %
	(calculated average)	€/m ² yr	±0	±0	+0,81	±0	±0
	Service systems	% of investment costs	±0 %	+2 %	-0,28 %	-5 %	-8,56 %
	(calculated average)	€/m ² yr	±0	+0,076	-0,167	-0,285	-0,257
	Total	€/m²yr	±0	+0,076	+0,643	-0,285	-0,257

5.2. Germany

Overview of technologies in solution sets, Germany

Technologies		DE typical NZEB	DE – SS2	DE – SS3	DE - SS7	DE – SS8
Main feature(s) of solution set		(base case)	Decentral service systems (heating, DHW and ventilation), roof PV panels and heat recovery from shower waste water -> reduced insulation levels	Central supply and exhaust ventilation system, air-air heat pump, electrical DHW heater and heat recovery from shower waste water -> reduced insulation levels	District heating -> reduced insulation levels	Exhaust air-water heat pump and condensing gas boiler, decentral fresh-water stations -> reduced insulation levels
Building envelope	External Walls	Limestone with external thermal insulation system (ETICS)	Limestone with external thermal insulation system (ETICS)	Limestone with external thermal insulation system (ETICS)	Limestone with external thermal insulation system (ETICS)	Limestone with external thermal insulation system (ETICS)
		U-value [W/(m ² K)]	0.10	0.16	0.16	0.16
Fenestration, incl. glazing, frame, spacer etc.	Description	Triple-glazed windows	Double-glazed windows	Double-glazed windows	Double-glazed windows	Double-glazed windows
		U-value [W/(m ² K)]	0.82	1.20	1.20	1.20
Roof	Average g-value (solar energy transmittance)		0.55	0.60	0.60	0.60
	Description	Saddle roof with insulation between and above the rafters	Saddle roof with insulation between and above the rafters	Saddle roof with insulation between and above the rafters	Saddle roof with insulation between and above the rafters	Saddle roof with insulation between and above the rafters
Cellar ceiling/ground slab	U-value [W/(m ² K)]	0.1	0.13	0.13	0.13	0.13
	Description	Insulated cellar ceiling	Insulated cellar ceiling	Insulated cellar ceiling	Insulated cellar ceiling	Insulated cellar ceiling
	U-value [W/(m ² K)]	0.20	0.25	0.25	0.25	0.25

Technologies		DE typical NZEB	DE – SS2	DE – SS3	DE - SS7	DE – SS8
Thermal bridges	Description	Overall (thermal bridge surcharge)	Overall (thermal bridge surcharge)	Overall (thermal bridge surcharge)	Overall (thermal bridge surcharge)	Overall (thermal bridge surcharge)
	ΔU value [W/(m ² K)]	0.03	0.03	0.03	0.03	0.03
Total building envelope ²²	H'_T [W/(m ² K)]	0.22	0.31	0.31	0.31	0.31
	National comparison value: $H'_{T,Ref} = 0.45$ W/(m ² K) $H'_{T,KW55} = 0.31$ W/(m ² K)					
Airtightness	Description	Good standard, test required	Good standard, test required	Good standard, test required	Good standard, test required	Good standard, test required
	Air-flow [l/(sm ²)] at 50 Pa	1.35	1.35	1.35	1.35	1.35
Heating	Air-change [h ⁻¹] at 50 Pa	2 h ⁻¹	2 h ⁻¹	2 h ⁻¹	2 h ⁻¹	2 h ⁻¹
	Generation	Gas condensing boiler, atmospheric burner (55/45°C) supported by the solar thermal collectors	Decentral electrical heating system	Exhaust air-air-heat pump	Connected to the district heating network (65/50°C)	Exhaust air-water heat pump and gas condensing boiler (55/45°C)
Distribution	Distribution	Insulated distribution pipes according to national standard	No distribution	Connected to the ventilation system	Insulated distribution pipes according to national standard	Insulated distribution pipes according to national standard
	Emission	Radiators, located at the external walls	Radiation based decentral panels (e.g. made of marble or glass)	Emission through the ventilation ducts	Radiators, located at the external walls	Radiators, located at the external walls
DHW	Generation	Gas condensing boiler in combination with	Decentral electrical continuous-flow water	Decentral electrical continuous-flow water	Connected to the district heating	Exhaust air-water heat pump

²² The average U-value should be calculated according to DIN V 18599 per m² thermal envelope, including thermal bridges.

Technologies		DE typical NZEB	DE – SS2	DE – SS3	DE - SS7	DE – SS8
		the solar thermal collectors	heater	heater	network (65/50°C)	
	Distribution	Insulated pipes (national standard) and circulation (24/7) using a pressure-controlled demand-driven pump	No distribution	No distribution	Insulated pipes (national standard) and circulation (24/7) using pressure-controlled demand-driven pump	Fresh water stations
	Emission	Standard fixtures and shower	Standard fixtures with heat recovery from the shower waste water	Standard fixtures with heat recovery from the shower waste water	Standard fixtures and shower	Standard fixtures and shower
Ventilation	Description	Mechanical exhaust ventilation, demand-controlled (0.24 l/(m ² s) / 0.45 h ⁻¹)	Decentral reversing air-flow ventilation with heat recovery (0.24 l/(m ² s) / 0.45 h ⁻¹)	Central supply and exhaust ventilation system with heat recovery via exhaust air heat pump (0.24 l/(m ² s) / 0.45 h ⁻¹)	Mechanical exhaust ventilation, demand-controlled (0.24 l/(m ² s) / 0.45 h ⁻¹)	Mechanical exhaust ventilation with heat recovery via exhaust air heat pump (0.24 l/(m ² s) / 0.45 h ⁻¹)
Cooling	Generation	None	None	None	None	None
	Distribution	None	None	None	None	None
	Emission	None	None	None	None	None
Lighting	Description	Not part of EP calculations, but heat load is included as a standard value.	Not part of EP calculations, but heat load is included as a standard value.	Not part of EP calculations, but heat load is included as a standard value.	Not part of EP calculations, but heat load is included as a standard value.	Not part of EP calculations, but heat load is included as a standard value.

Technologies		DE typical NZEB	DE – SS2	DE – SS3	DE - SS7	DE – SS8
RES	Solar thermal	47 m ² of flat-plate solar thermal collectors which contribute 11,189 kWh of net energy to the DHW and 2,742 kWh to the heating system	None	None	None	None
	PV	None	130 m ² , 17.6 kWp, monocrystalline, south-oriented, 15° tilt-angle. Energy production 15,948 kWh	None	None	10 m ² , 1.35 kWp, monocrystalline, south-oriented, 15° tilt-angle. Energy production 1.227 kWh
	Biomass	None	None	None	None	None
	Wind turbine	None	None	None	None	None
	Ambient energy	None	None	None	None	None
		Description (area, type of system, energy production [kWh], etc.)				
	Description (type of system, energy production [kWh], biomass source, etc.)					
	Description (type and size of system, energy production [kWh], etc.)					
	Description (other types of RES in your national regulation, e.g. heat recovery of the ventilation system, use of exhaust air, external air, ground or ground water by heat pumps, etc.)		Heat recovery of the ventilation system and heat recovery from shower waste water	Heat recovery of the ventilation system via the air-air heat pump and heat recovery from shower waste water.	None	Exhaust air heat recovery through the air-water heat pump to deliver DHW

Calculated energy and cost values

Characteristic values		DE typical NZEB (base case)	DE – SS2	DE – SS3	DE – SS7	DE – SS8
All calculations are based on the net floor area						
Net energy ²³	Heating	kWh/(m ² ·yr)	20.42	21.24	26.16	34.39
	DHW	kWh/(m ² ·yr)	15.00	15.00	15.00	15.00
	Cooling	kWh/(m ² ·yr)				
	(Lighting*)	kWh/(m ² ·yr)				
	Total	kWh/(m²·yr)	35.50	36.24	41.16	49.39

²³ **Net Energy** consumption is energy delivered inside the building, without distribution losses and without PEF.

Characteristic values		DE typical NZEB	DE – SS2	DE – SS3	DE – SS7	DE – SS8
Final energy ²⁴	Heating (incl. auxiliary energy)	kWh/(m ² yr)	22.44	14.07	37.35	30.22
	DHW (incl. auxiliary energy)	kWh/(m ² yr)	11.81	11.81	26.20	7.09
	Cooling (incl. auxiliary energy)	kWh/(m ² yr)				
	Ventilation	kWh/(m ² yr)	1.93	1.12	1.93	2.21
	PV electricity (EPBD – self use)	kWh/(m ² yr)	13.35			1.25
	PV electricity (total)		16.19			1.25
	(Household electricity*)	kWh/(m ² yr)	25.00	25.00	25.00	25.00
	Total EPBD	kWh/(m²yr)	22.83	27.00	65.48	38.27
	Total (incl. other energy uses)	kWh/(m²yr)	47.83	52.00	90.48	63.27
Primary energy ²⁵	District heating	kWh/(m ² yr)			44.22	
	Gas	kWh/(m ² yr)	47.61			28.95
	Electricity (EPBD)	kWh/(m ² yr)	5.96	41.09	4.17	21.53
	Electricity (other)	kWh/(m ² yr)	45.00	45.00	45.00	45.00
	Total EPBD ²⁶	kWh/(m²yr)	53.57	41.09	48.60	50.48
	Total (incl. other energy uses)	kWh/(m²yr)	98.57	86.09	93.39	95.48
Energy costs	District heating	€/m ² yr			6.32	
	Gas	€/m ² yr	2.35			1.43
	Electricity (EPBD) ⁵	€/m ² yr	0.98	6.43	0.68	2.79
	Electricity (other)	€/m ² yr	7.36	7.36	7.36	7.36
	Total EPBD ⁵	€/m²yr	3.33	6.43	6.91	4.22
	Total (incl. other energy uses)	€/m²yr	10.69	14.08	14.27	11.58

²⁴ **Final energy** consumption is the total energy consumed by end users. Thus, the energy that reaches the final consumer's energy meter and excludes energy used by the energy sector itself, i.e. without PEF.

²⁵ **Primary Energy** Factors describes the efficiency of converting energy from primary sources (like fossil fuels...) to secondary energy carriers (e.g. electricity) that provides the services delivered to the end user to heat, cool, ventilate etc. the building (EN ISO 52000-1).

²⁶ Final energy demand included in the national EPBD calculations.

Characteristic values		DE typical NZEB	DE – SS2	DE – SS3	DE – SS7	DE – SS8
Investment costs	Building envelope components	€/m ²	366	366	366	366
	Service systems	€/m ²	117	144	118	157
	Total	€/m²	483	510	484	523
Maintenance costs	Building envelope components	%/yr of investment costs	2	2	2	2
	(calculated average)	€/yr	7,207	7,207	7,207	7,207
	Service systems	% of investment costs	1.45	1.75	2.07	1.35
	(calculated average)	€/yr	2,028	2,925	1,575	2,903
Total	€/yr	10,337	9,235	10,132	8,782	10,110

* not part of the building energy performance calculation in any of the 4 countries, but used to calculate the possible energy cost savings due to PV

5.3. Italy

5.3.1. Rome

Technologies	Typical NZEB (base case, ROME)	IT - SS1	IT-SS2	IT-SS3	IT-SS4
Main feature(s) of solution set		Low-tech thermal driven solution with variations in the composition of the external walls and the technology of the windows. Use of condensing boiler for both heating and DHW production.	Electricity driven solution with variations in the composition of the external walls and the technology of the windows. Heat pump for both heating and DHW supply. No use of solar thermal collectors.	Electricity driven solution (outlaw) with variations in the composition of the external walls and the technology of the windows. Electric radiators for heating supply.	Low-tech thermal driven solution (outlaw) with variations in the composition of the external walls and the technology of the windows. Use of condensing boiler for both heating and DHW production. Reduction

Technologies		Typical NZEB (base case, ROME)	IT - SS1	IT-SS2	IT-SS3	IT-SS4
Main feature(s) of solution set						
Building envelope	External Walls	Description Multilayer envelope composed by two brick walls with an EPS thermal coating.	Different technology based on large autoclaved concrete bricks	Different technology based on large autoclaved concrete bricks	Different technology based on large autoclaved concrete bricks	Different technology based on large autoclaved concrete bricks
		U-value [W/(m ² K)]	0.28	0.28	0.28	0.28
Fenestration, incl. glazing, frame, spacer etc.	Description	Argon-filled double-glazed windows	Mono-block windows (assembled window with its own roller shutter box)	Mono-block windows (assembled window with its own roller shutter box)	Mono-block windows (assembled window with its own roller shutter box)	Mono-block windows (assembled window with its own roller shutter box)
	U-value [W/(m ² K)]	1.46	1.46	1.46	1.46	1.46
Roof	Average normal g-value (solar energy transmittance)	0.6	0.6	0.6	0.6	0.6
	Description	Tilted roof insulated with XPS	Tilted roof insulated with XPS	Tilted roof insulated with XPS	Tilted roof insulated with XPS	Tilted roof insulated with XPS
Cellar ceiling/ground slab	U-value [W/(m ² K)]	0.26	0.26	0.26	0.26	0.26
	Description	Slab on ground insulated with XPS	Slab on ground insulated with XPS	Slab on ground insulated with XPS	Slab on ground insulated with XPS	Slab on ground insulated with XPS
Thermal bridges	U-value [W/(m ² K)]	0.28	0.28	0.28	0.28	0.28
	Description	Around windows: 0.03 W/mk Foundations: 0.0 W/mk	Around windows: 0.03 W/mk Foundations: 0.0 W/mk	Around windows: 0.03 W/mk Foundations: 0.0 W/mk	Around windows: 0.03 W/mk Foundations: 0.0 W/mk	Around windows: 0.03 W/mk Foundations: 0.0 W/mk
Line losses [W/mK] / ΔU value [W/m ² K]						

Technologies		Typical NZEB (base case, ROME)				IT - SS1	IT-SS2	IT-SS3	IT-SS4
Main feature(s) of solution set		Average U-value [W/(m ² K)] National comparison value 0.61 W/(m ² K)		0.34		0.34		0.34	
Airtightness		Description		National NZEB standard					
		Air-flow [l/sm ²]		0 in case of natural ventilation – no information about the air-tightness.					
		Air-change [h ⁻¹]		/					
Technical Building Services (TBS) systems	Heating	Generation	Central heating supply: 1) Air-water heat pump (COP 3.28). Cut out temperature: 3°-45° 2) Gas condensing boiler as backup system efficiency 0.95 (100 %) - 1.03 (30 %) 3) PV panels	1) Gas condensing boiler, replacing the air-water heat pump, efficiency 0.95 (100 %) - 1.03 (30 %) 2) PV panels	1) Air water heat pump for both heating and DHW supply COP 3.28 2) Gas condensing boiler as backup system efficiency 0.95 (100 %) - 1.03 (30 %) 3) PV panels	ABSENT 2) PV panels	1) Gas condensing boiler, replacing the air-water heat pump, efficiency 0.95 (100 %) - 1.03 (30 %) 2) PV panels		
		Distribution	Insulated distribution pipes according to national standard	Insulated distribution pipes according to national standard	Insulated distribution pipes according to national standard		Insulated distribution pipes according to national standard		
		Emission	Floor heating	Floor heating instead of heating floor. Efficiency 0.96 (from	Aluminium radiators instead of heating floor. Efficiency 0.96 (from	Low-temperature aluminium radiators instead of heating floor.	Electric radiators Efficiency 1	Aluminium radiators instead of heating floor. Efficiency 0.96 (from	

²⁷ The average U-value should be calculated according to EN ISO 52018-1:2017 per m² thermal envelope, including thermal bridges.

Technologies		Typical NZEB (base case, ROME)	IT - SS1	IT-SS2	IT-SS3	IT-SS4
Main feature(s) of solution set						
DHW	Generation	Central DHW Supply: 1) Gas furnace condensing efficiency 0.95 (100 %) - 1.03 (30 %) 2) Solar collectors	Central DHW Supply: 1) Gas furnace condensing efficiency 0.95 (100 %) - 1.03 (30 %) 2) Solar collectors	1) Air water heat pump for both heating and DHW supply COP 3.28 2) Gas condensing boiler as backup system efficiency 0.95 (100 %) - 1.03 (30 %)	1) Gas condensing boiler as backup system efficiency 0.95 (100 %) - 1.03 (30 %) 2) Solar collectors	Central DHW Supply: 1) Gas furnace condensing efficiency 0.95 (100 %) - 1.03 (30 %) 2) Solar collectors
	Distribution	Insulated distribution pipes according to national standard	Insulated distribution pipes according to national standard	Insulated distribution pipes according to national standard	Insulated distribution pipes according to national standard	Insulated distribution pipes according to national standard
Ventilation	Emission	Standard fixtures and shower	Standard fixtures and shower	Standard fixtures and shower	Standard fixtures and shower	Standard fixtures and shower
	Description	Natural ventilation - Ventilation rate: 1785 m ³ /h - Ventilation rate/ GFA: 0.22 l/(sm ²); 0.3 ACH	Natural ventilation - Ventilation rate: 1785 m ³ /h - Ventilation rate/ GFA: 0.22 l/(sm ²); 0.3 ACH	Natural ventilation - Ventilation rate: 1785 m ³ /h - Ventilation rate/ GFA: 0.22 l/(sm ²); 0.3 ACH	Natural ventilation - Ventilation rate: 1785 m ³ /h - Ventilation rate/ GFA: 0.22 l/(sm ²); 0.3 ACH	Natural ventilation - Ventilation rate: 1785 m ³ /h - Ventilation rate/ GFA: 0.22 l/(sm ²); 0.3 ACH
Cooling	Generation	None	None	None	None	None
	Distribution	None	None	None	None	None

Technologies		Main feature(s) of solution set	Typical NZEB (base case, ROME)	IT - SS1	IT-SS2	IT-SS3	IT-SS4	
	Emission							
RES	Lighting	Description	None	Not part of EP calculations	Not part of EP calculations	Not part of EP calculations	None	
	Solar thermal	Description (area, type of system, energy production [kWh], etc.)	vacuum solar collector Mounted on the tilted roof (-30° and 18°), on the south-east and south-west oriented pitches 15 Modules 27 m ²	vacuum solar collector Mounted on the tilted roof (-30° and 18°), on the south-east and south-west oriented pitches 19 Modules 34 m ²	vacuum solar collector Mounted on the tilted roof (-30° and 18°), on the south-east and south-west oriented pitches 18 Modules 33 m ²	vacuum solar collector Mounted on the tilted roof (-30° and 18°), on the south-east and south-west oriented pitches 19 Modules 34 m ²	vacuum solar collector Mounted on the tilted roof (-30° and 18°), on the south-east and south-west oriented pitches 19 Modules 34 m ²	
	PV	Description (area, type of system, energy production [kWh], peak power [kW], etc.)	Mounted on the tilted roof, on the south-east and south-west oriented pitches 89 Modules azimuth 120° tilt 18° 142 m ² 22500 kWh 22 kWp	Mounted on the tilted roof, on the south-east and south-west oriented pitches 89 Modules azimuth 120° tilt 18° 142 m ² 22500 kWh 22 kWp	Mounted on the tilted roof, on the south-east and south-west oriented pitches 89 Modules azimuth 120° tilt 18° 142 m ² 22500 kWh 22 kWp	Mounted on the tilted roof, on the south-east and south-west oriented pitches 89 Modules azimuth 120° tilt 18° 142 m ² 22500 kWh 22 kWp	Mounted on the tilted roof, on the south-east and south-west oriented pitches 100 Modules azimuth 120° tilt 18° 163 m ² 25800 kWh	Mounted on the tilted roof, on the south-east and south-west oriented pitches 6 Modules azimuth 120° tilt 18° 9.6 m ² 1521 kWh
	Biomass	Description (type of system, energy production [kWh], biomass source, etc.)	None	None	None	None	None	None
Wind turbine	Description: (type and size of system, energy production [kWh], etc.)	None	None	None	None	None	None	
	Ambient energy	Description (other types of RES in your national regulation,	None	None	None	None	None	

Technologies		Typical NZEB (base case, ROME)	IT - SS1	IT-SS2	IT-SS3	IT-SS4
Main feature(s) of solution set						
e.g. heat recovery of the ventilation system, use of exhaust air, external air, ground or ground water by heat pumps, etc.)						

Calculated energy and cost values

Characteristic values		Typical NZEB (base case, ROME)	IT - SS1	IT-SS2	IT-SS3	IT-SS4
All numbers are based on the net indoor area						
Net energy ²⁸	Heating	kWh/(m ² ·yr)	5.22	5.12	5.28	5.22
	DHW	kWh/(m ² ·yr)	13.63	13.63	13.63	13.63
	Cooling	kWh/(m ² ·yr)	/	/	/	/
	(Lighting*)	kWh/(m ² ·yr)	/	/	/	/
	Total	kWh/(m²·yr)	18.76	18.85	18.75	18.91
Final energy ²⁹	Heating (incl. aux. energy)	kWh/(m ² ·yr)	4.59	1.92	4.8	4.59
	DHW (incl. aux. energy)	kWh/(m ² ·yr)	9.13	6.65	7.61	7.15
	Cooling (incl. aux. energy)	kWh/(m ² ·yr)	/	/	/	/
	Ventilation	kWh/(m ² ·yr)	/	/	/	/
	(Lighting*)	kWh/(m ² ·yr)	/	/	/	/
	(Household electricity*)	kWh/(m ² ·yr)	/	/	/	/
Total EPBD	kWh/(m²·yr)	11.05	11.74	8.57	12.41	11.74

²⁸ **Net Energy** consumption is energy delivered inside the building, without distribution losses and without PEF.

²⁹ **Final energy** consumption is the total energy consumed by end users. Thus, the energy that reaches the final consumer's energy meter and excludes energy used by the energy sector itself, i.e. without PEF.



Characteristic values		Typical NZEB (base case, ROME)	IT - SS1	IT-SS2	IT-SS3	IT-SS4
All numbers are based on the net indoor area						
Total (incl. other energy uses)	kWh/(m ² yr)	/				

Characteristic values		IT - SS1	IT - SS2	IT - SS3	IT - SS4
All numbers are based on the net indoor area		IT - SS1	IT - SS2	IT - SS3	IT - SS4
Primary energy ³⁰	Typical NZEB (base case, ROME)	IT - SS1	IT - SS2	IT - SS3	IT - SS4
District heating	kWh/(m ² yr)	/	/	/	/
Gas	kWh/(m ² yr)	12.33	0.4	8.04	12.43
Electricity (EPBD)	kWh/(m ² yr)	/	5.51	6.62	/
Electricity (other)	kWh/(m ² yr)				
Heating from RES	kWh/(m ² yr)	0.04	3.59	3.01	0.03
DHW from RES	kWh/(m ² yr)	12.43	18.28	11.95	12.41
Total EPBD³¹ (from non RES)	kWh/(m²yr)	12.33	5.91	14.66	12.43
Total EPBD³² (including both non RES and RES)	kWh/(m²yr)	24.8	27.78	29.62	24.9
Total (incl. other energy uses)	kWh/(m²yr)	/	/	/	/
District heating	€/ (m ² yr)	/	/	/	/
Gas	€/ (m ² yr)	0.85	0.03	0.55	0.85
Electricity (EPBD) ⁵	€/ (m ² yr)	/	0.58	0.69	0.02
Electricity (other)	€/ (m ² yr)	/	/	/	/
Total EPBD⁵	€/ (m²yr)	0.85	0.61	1.25	0.87
Total (incl. other energy uses)	€/ (m²yr)	/	/	/	/
Building envelope	€/m ²	1210	1210	1210	1210
Service systems	€/m ²	346	357	334	331
Total	€/m²	1556	1567	1542	1541
Investment costs					

³⁰ **Primary Energy** Factors describes the efficiency of converting energy from primary sources (like fossil fuels...) to secondary energy carriers (e.g. electricity) that provides the services delivered to the end user to heat, cool, ventilate etc. the building (EN ISO 52000-1).

³¹ Final energy demand included in the national EPBD calculations.

³² Final energy demand included in the national EPBD calculations.

Characteristic values		IT - SS1	IT - SS2	IT - SS3	IT - SS4
All numbers are based on the net indoor area					
Maintenance costs	Building envelope components (calculated average)	0.5	0.5	0.5	0.5
	% of investment costs	13038	12868	12868	12868
	Service systems (calculated average)	1.4	1.3	0.9	1.1
	€/yr	12149	9871	6355	7744
Total	24299	22739	19223	20612	

5.3.2. Turin

Technologies	IT - SS1	IT - SS2	IT - SS3	IT - SS4	IT - SS5
Main feature(s) of solution set	<p>Typical NZEB (TURIN)</p> <p>Low-tech thermal driven solution with variations in the composition of the external walls and the technology of the windows. Use of the condensing boiler for both heating and DHW production. Combined use of solar collectors both for heating and DHW</p>	<p>IT - SS2</p> <p>Low-tech thermal driven solution with variations in the composition of the external walls and the technology of the windows and extra insulation (SuperNzeb envelope). Use of condensing boiler for both heating and DHW production. Combined use of solar collectors both for heating and DHW. Mechanical extract ventilation.</p>	<p>IT - SS3</p> <p>Electricity driven solution with variations in the composition of the external walls and the technology of the windows. Air water heat pump for both heating and DHW supply. No solar collectors.</p>	<p>IT - SS4</p> <p>Electricity driven solution with variations in the composition of the external walls and the technology of the windows and extra insulation (SuperNzeb envelope). Air water heat pump for both heating and DHW supply. No solar collectors.</p>	<p>IT - SS5</p> <p>Electricity driven solution (out-law) with variations in the composition of the external walls and the technology of the windows and extra insulation (SuperNzeb envelope). Electric radiators for heating supply.</p>

Technologies		Typical NZEB (TURIN)	IT - SS1	IT-SS2	IT-SS3	IT-SS4	IT-SS5
Building envelope	External Walls	Description Multilayer envelope composed by two brick walls with an EPS thermal coating.	Different technology based on large autoclaved concrete bricks	Different technology, based on large autoclaved concrete bricks characterized by a lower transmittance (Supernzeb solution)	Different technology based on large autoclaved concrete bricks	Different technology, based on large autoclaved concrete bricks characterized by a lower transmittance (Supernzeb solution)	Different technology, based on large autoclaved concrete bricks characterized by a lower transmittance (Supernzeb solution)
	Fenestration, incl. glazing, frame, spacer etc.	U-value [W/m ² K] Argon-filled double-glazed windows 1.40 0.6	Different technology based on large autoclaved concrete bricks with its own roller shutter box) 1.40 0.6	Mono-block windows (assembled window with its own roller shutter box) 1.40 0.6	Mono-block windows (assembled window with its own roller shutter box) 1.40 0.6	Mono-block windows (assembled window with its own roller shutter box) 1.40 0.6	Mono-block windows (assembled window with its own roller shutter box) 1.40 0.6
Roof	Description Tilted roof insulated with XPS	Tilted roof insulated with XPS	Tilted roof insulated with XPS	Addition of thermal insulation for reducing transmittance (Supernzeb solution)	Tilted roof insulated with XPS	Addition of thermal insulation for reducing transmittance	Addition of thermal insulation for reducing transmittance (Supernzeb solution)

Technologies		Typical NZEB (TURIN)	IT - SS1	IT-SS2	IT-SS3	IT-SS4	IT-SS5
	U-value [W/(m ² K)]	0.21	0.21	0.105	0.21	(Supernzeb solution) 0.105	0.105
Cellar ceiling/ground slab	Description	Slab on ground insulated with XPS	Slab on ground insulated with XPS	Addition of thermal insulation for reducing transmittance (Supernzeb solution)	Slab on ground insulated with XPS	Addition of thermal insulation for reducing transmittance (Supernzeb solution)	Addition of thermal insulation for reducing transmittance (Supernzeb solution)
	U-value [W/(m ² K)]	0.24	0.24	0.12	0.24	0.12	0.12
Thermal bridges	Description	Around windows: 0.03 W/mK Foundations: 0.0 W/mK					
	Line losses [W/(mK)] / ΔU value [W/(m ² K)]						
Envelope total ³³	Average U-value [W/(m ² K)] National comparison value 0.59 [W/(m ² K)]	0.30	0.30	0.24	0.30	0.24	0.24
Airtightness	Description	National NZEB standard					
	Air-flow [l/(sm ²) at 50 Pa]	0.77	0.77	0.77	0.77	0.77	0.77
	Air-change [h ⁻¹]	1.08	1.08	1.08	1.08	1.08	1.08

³³ The average U-value should be calculated according to EN ISO 52018-1:2017 per m² thermal envelope, including thermal bridges.

Technologies		Typical NZEB (TURIN)	IT - SS1	IT-SS2	IT-SS3	IT-SS4	IT-SS5
Technical Building Services (TBS) systems	Heating	Central heating supply: 1) Air-water heat pump (COP 3.28). Cut out temperature: 0°-45° 2) Gas condensing boiler as backup system efficiency 0.95 (100 %) - 1.03 (30 %) 3) PV panels	1) Gas condensing boiler, replacing the air-water heat pump, efficiency 0.95 (100 %) - 1.03 (30 %) 2) PV panels	1) Gas condensing boiler, replacing the air-water heat pump, efficiency 0.95 (100 %) - 1.03 (30 %) 2) PV panels	1) Air water heat pump for both heating and DHW supply COP 3.28 in standard conditions Cut out temperature: 0°-45° 2) Gas condensing boiler as back-up system efficiency 0.95 (100 %) - 1.03 (30 %) 3) PV panels	1) Air water heat pump for both heating and DHW supply COP 3.28 in standard conditions Cut out temperature: 0°-45° 2) Gas condensing boiler as back-up system efficiency 0.95 (100 %) - 1.03 (30 %) 3) PV panels	Absent 1)PV panels
	Distribution	Insulated distribution pipes according to national standard	Insulated distribution pipes according to national standard	Insulated distribution pipes according to national standard	Insulated distribution pipes according to national standard	Insulated distribution pipes according to national standard	/
	Emission	Floor heating	Aluminium radiators instead of heating floor. Efficiency 0.96 (from UNI/TS 11300-2)	Aluminium radiators instead of heating floor. Efficiency 0.96 (from UNI/TS 11300-2)	Aluminium radiators instead of heating floor. Efficiency 0.96 (from UNI/TS 11300-2)	Low-temperature aluminium radiators instead of heating floor. Efficiency 0.96 (from UNI/TS	Low-temperature aluminium radiators instead of heating floor. Efficiency 0.96 (from UNI/TS

Technologies		Typical NZEB (TURIN)	IT - SS1	IT-SS2	IT-SS3	IT-SS4	IT-SS5
DHW	Generation	Central DHW Supply: 1) Gas furnace condensing efficiency 0.95 (100 %) - 1.03 (30 %) 2) Solar collectors	No change respect to the base case	No change respect to the base case	(from UNI/TS 11300-2) 1) Air water heat pump for both heating and DHW supply COP 3.28 in standard conditions 2) Gas condensing boiler as back-up system efficiency 0.95 (100 %) - 1.03 (30 %)	1) Air water heat pump for both heating and DHW supply COP 3.28 in standard conditions 2) Gas condensing boiler as back-up system efficiency 0.95 (100 %) - 1.03 (30 %)	1) Gas condensing boiler as backup system efficiency 0.95 (100 %) - 1.03 (30 %) 2) Solar collectors
	Distribution	Insulated distribution pipes according to national standard	Insulated distribution pipes according to national standard	Insulated distribution pipes according to national standard	Insulated distribution pipes according to national standard	Insulated distribution pipes according to national standard	Insulated distribution pipes according to national standard
	Emission	Standard fixtures and shower	Standard fixtures and shower	Standard fixtures and shower	Standard fixtures and shower	Standard fixtures and shower	Standard fixtures and shower
Ventilation		MVHR - Ventilation rate:2090	MVHR - Ventilation rate:2090 m ³ /h	MEV Mechanical extraction ventilation	MVHR - Ventilation rate:2090 m ³ /h	MEV Mechanical extraction ventilation	MVHR - Ventilation rate:2090 m ³ /h

Technologies	Typical NZEB (TURIN)	IT - SS1	IT-SS2	IT-SS3	IT-SS4	IT-SS5
RES	Solar thermal vacuum solar collector mounted on the tilted roof (-30° and 18°), on the south-east and south-west oriented pitches 22 modules 40 m ²	vacuum solar collector mounted on the tilted roof (-30° and 18°), on the south-east and south-west oriented pitches Combined use both for heating and DHW 44 modules 79 m ²	vacuum solar collector mounted on the tilted roof (-30° and 18°), on the south-east and south-west oriented pitches Combined use both for heating and DHW 44 modules 79 m ²	Solar collectors not installed	Solar collectors not installed	vacuum solar collector mounted on the tilted roof (-30° and 18°), on the south-east and south-west oriented pitches 30 modules 54 m ²
PV	Mounted on the tilted roof, on the south-east and south-west oriented pitches 89 modules 120° tilt 18° 142 m ²	Mounted on the tilted roof, on the south-east and south-west oriented pitches 89 modules 120° tilt 18° 142 m ²	Mounted on the tilted roof, on the south-east and south-west oriented pitches 89 modules 120° tilt 18° 142 m ²	Mounted on the tilted roof, on the south-east and south-west oriented pitches 89 modules 120° tilt 18° 142 m ²	Mounted on the tilted roof, on the south-east and south-west oriented pitches 89 modules 120° tilt 18° 142 m ²	Mounted on the tilted roof, on the south-east and south-west oriented pitches 100 modules 120° tilt 18° 160 m ²
Biomass	None	None	None	None	None	None
Wind turbine	None	None	None	None	None	None

Technologies	Typical NZEB (TURIN)	IT - SS1	IT-SS2	IT-SS3	IT-SS4	IT-SS5
Ambient energy	Heat recovery of the ventilation system	Heat recovery of the ventilation system	None	Heat recovery of the ventilation system	None	Heat recovery of the ventilation system

Calculated energy and cost values

Characteristic values		IT typical NZEB (base case) TURIN	IT - SS1	IT-SS2	IT-SS3	IT-SS4	IT-SS5
All numbers are based on the net indoor area							
Net energy ³⁴	Heating	kWh/(m ² yr)	13.37	13.63	13.37	13.63	7.33
	DHW	kWh/(m ² yr)	16	16	16	16	16
	Cooling	kWh/(m ² yr)	/	/	/	/	/
	(Lighting*)	kWh/(m ² yr)	/	/	/	/	/
	Total	kWh/(m²yr)	29.37	29.63	29.37	29.63	23.33

³⁴ **Net Energy** consumption is energy delivered inside the building, without distribution losses and without PEF.

Characteristic values		IT typical NZEB (base case) TURIN	IT - SS1	IT-SS2	IT-SS3	IT-SS4	IT-SS5
All numbers are based on the net indoor area							
Final energy ³⁵	Heating (incl. auxiliary energy)	kWh/(m ² yr)	9.85	9.86	7.2	7.32	7.1
	DHW (incl. auxiliary energy)	kWh/(m ² yr)	6.9	6.7	9.22	9.22	7.55
	Cooling (incl. auxiliary energy)	kWh/(m ² yr)	/	/	/	/	/
	Ventilation	kWh/(m ² yr)					
	(Lighting*)	kWh/(m ² yr)	/	/	/	/	/
	(Household electricity*)	kWh/(m ² yr)	/	/	/	/	/
	Total EPBD	kWh/(m²yr)	17.78	16.75	16.56	16.42	16.54
Total (incl. other energy uses)	kWh/(m²yr)	/	/				

³⁵ **Final energy** consumption is the total energy consumed by end users. Thus, the energy that reaches the final consumer's energy meter and excludes energy used by the energy sector itself, i.e. without PEF.

Characteristic values		IT typical NZEB (base case) TURIN	IT - SS1	IT-SS2	IT-SS3	IT-SS4	IT-SS5
All numbers are based on the net indoor area							
Primary energy ³⁶	District heating	kWh/(m ² yr)	/	/	/	/	/
	Gas	kWh/(m ² yr)	17.64	17.38	5.11	5.19	8.02
	Electricity (EPBD)	kWh/(m ² yr)	0.04	/	13.96	12.67	13.04
	Electricity (other)	kWh/(m ² yr)	/	/	/	/	/
	Heating from RES	kWh/(m ² yr)	2.35	2.5	7.4	7.5	3.94
	DHW from RSE	kWh/(m ² yr)	15.49	15.76	19.2	19.3	15.13
	Ventilation from RES	kWh/(m ² yr)	2.12	0.89	1.72	0.73	2.6
	Total EPBD³⁷ (from non-RES)	kWh/(m²yr)	17.68	17.38	19.07	17.86	21.05
	Total EPBD³⁸ (including both non-RES and RES)	kWh/(m²yr)	37.64	36.53	47.39	45.4	42.72
	Total (incl. other energy uses)	kWh/(m²yr)	/	/	/	/	/
Energy costs	District heating	€/m ² yr	/	/	/	/	/
	Gas	€/m ² yr	1.21	1.20	0.35	0.36	0.55
	Electricity (EPBD) ⁵	€/m ² yr	0.006	/	1.46	1.32	1.37
	Electricity (other)	€/m ² yr	/	/	/	/	/
	Total EPBD⁵	€/m²yr	1.22	1.20	1.81	1.68	1.92
	Total (incl. other energy uses)	€/m²yr	/	/	/	/	/
Investment costs	Building envelope	€/m ²	1222	1251	1222	1251	1251

³⁶ **Primary Energy** Factors describes the efficiency of converting energy from primary sources (like fossil fuels...) to secondary energy carriers (e.g. electricity) that provides the services delivered to the end user to heat, cool, ventilate etc. the building (EN ISO 52000-1).

³⁷ Final energy demand included in the national EPBD calculations.

³⁸ Final energy demand included in the national EPBD calculations.

Characteristic values		IT typical NZEB (base case) TURIN	IT - SS1	IT-SS2	IT-SS3	IT-SS4	IT-SS5
All numbers are based on the net indoor area							
	components						
	Service systems	€/m ²	408	380	406	378	386
	Total	€/m²	1630	1631	1628	1629	1637
Maintenance costs	Building envelope components (calculated average)	% of investment costs	0.5	0.5	0.5	0.5	0.5
	Service systems (calculated average)	€/yr	12996	13304	12996	13304	13304
		% of investment costs	1.6	1.4	1.7	1.7	1.4
		€/yr	12149	11315	14680	13668	11494
	Total	€/yr	25145	24619	27676	26972	24798

Technologies		Typical NZEB (base case)	SI - SS1	SI - SS2	SI - SS3	SI - SS4
ceiling/ ground slab		internal thermal insulation system 0.14	internal thermal insulation system 0.14	internal thermal insulation system 0.14	internal thermal insulation system 0.14	internal thermal insulation system 0.14
	Thermal bridges	Thermal bridges were considered with the increase of thermal conductivity of building envelope by 0.06 W/m ² K	Thermal bridges were considered with the increase of thermal conductivity of building envelope by 0.06 W/m ² K	Thermal bridges were considered with the increase of thermal conductivity of building envelope by 0.06 W/m ² K	Thermal bridges were considered with the increase of thermal conductivity of building envelope by 0.06 W/m ² K	Thermal bridges were considered with the increase of thermal conductivity of building envelope by 0.06 W/m ² K
Envelope total ³⁹		Line losses [W/(mK)] / ΔU value [W/(m ² K)] 0.06	0.06	0.06	0.06	0.06
Specific coefficient of transmission thermal losses [W/(m ² K)]		0.413 (National comparison value: 0.473)	0.413 (National comparison value: 0.473)	0.333 (National comparison value: 0.473)	0.333 (National comparison value: 0.473)	0.333 (National comparison value: 0.473)
Air-tightness	Description					
	Air-flow [l/(sm ²) at 50 Pa]	1.42	0.71	0.71	0.71	0.71
Heating	Air-change [h ⁻¹]	2	1	1	1	1
	Generation	Connection to the gas heating network – gas condensing boiler	Connection to the district heating network	Air heat pump	Gas	Air heat pump
Technical Building Services (TBS) systems	Distribution	Insulated distribution pipes; generator and thermal storage tank	Insulated distribution pipes; generator and thermal storage tank	Insulated distribution pipes; generator and thermal storage tank	Insulated distribution pipes; generator and thermal storage tank	Insulated distribution pipes; generator and thermal storage tank

³⁹ The average U-value should be calculated according to EN ISO 52018-1:2017 per m² thermal envelope, including thermal bridges.

Specific coefficient of transmission thermal losses [W/m²K] – is the ratio between the coefficient of transmission thermal losses (calculated according to SIST EN 13790) and the total external surface of the building.

Technologies		Typical NZEB (base case)	SI - SS1	SI - SS2	SI - SS3	SI - SS4
		are placed in boiler room	are placed in boiler room	are placed in boiler room	are placed in boiler room	are placed in boiler room
DHW	Emission	Floor heating	Floor heating	Floor heating	Floor heating	Floor heating
	Generation	Heating through the gas condensing boiler	Heating through the district heating network	Air heat pump	Air heat pump	Air heat pump
	Distribution	Insulated pipes, circulation, pump in heated room	Insulated pipes, circulation, pump in heated room	Insulated pipes, circulation, pump in heated room	Insulated pipes, circulation, pump in heated room	Insulated pipes, circulation, pump in heated room
Ventilation	Emission	Standard fixtures and shower	Standard fixtures and shower	Standard fixtures and shower	Standard fixtures and shower	Standard fixtures and shower
	Description	Hygro-sensible ventilation system (0.25 l/m ² s)	Mechanical ventilation with heat recovery (0.5 l/m ² s; 85 % efficiency)	Mechanical ventilation with heat recovery (0.5 l/m ² s; 85 % efficiency)	Mechanical ventilation with heat recovery (0.5 l/m ² s; 85 % efficiency)	Hygro-sensible ventilation system (0.25 l/m ² s)
Cooling	Generation	None	None	None	None	None
	Distribution	None	None	None	None	None
	Emission	None	None	None	None	None
Lighting		Lighting system 2 W/m ² ; operating hours: 1500 h (inputs needed for net energy calculation)	Lighting system 2 W/m ² ; operating hours: 1500 h (inputs needed for net energy calculation)	Lighting system 2 W/m ² ; operating hours: 1500 h (inputs needed for net energy calculation)	Lighting system 2 W/m ² ; operating hours: 1500 h (inputs needed for net energy calculation)	Lighting system 2 W/m ² ; operating hours: 1500 h (inputs needed for net energy calculation)

Technologies		Typical NZEB (base case)	SI - SS1	SI - SS2	SI - SS3	SI - SS4
RES	Solar thermal	190 m ² ; vacuum solar collector; 25,252 kWh/yr; for DHW usage	None	None	None	None
	PV	None	None	None	None	200 m ² ; Polycrystalline silicon; 28949 kWh/yr; 31 kWp
	Biomass	None	None	None	None	None
	Wind turbine	None	None	None	None	None
	Ambient energy	None	None	Air Heat Pump: COP depends on outside temperature: - -7°C: 2,7 - 2°C: 3,1 - 7°C: 3,7 - 15°C: 4,3	Air Heat Pump: COP depends on outside temperature: - -7°C: 2,7 - 2°C: 3,1 - 7°C: 3,7 - 15°C: 4,3	Air Heat Pump: COP depends on outside temperature: - -7°C: 2,7 - 2°C: 3,1 - 7°C: 3,7 - 15°C: 4,3

Calculated energy and cost values, Slovenia

Characteristic values		SI typical NZEB (base case)	SI - SS1	SI - SS2	SI - SS3	SI - SS4
All numbers are based on the net indoor area		Heat supply: Gas furnace condensing; Solar collectors for DHW; Use of hygro-sensible ventilation system; double glazing windows	District heating as generation for heating and DHW; Use of mechanical ventilation with 85 % heat recovery	Air heat pump as generation for heating and DHW; Use of mechanical ventilation with 85 % heat recovery; Triple glazing windows	Air heat pump as generation for DHW; Gas furnace condensing for heating; Use of mechanical ventilation with 85 % heat recovery; Triple glazing windows; better airtightness	Air heat pump as generation for heating and DHW; Roof PV panels; Use of hygro-sensible ventilation system; Triple glazing windows
Net energy ⁴⁰	Heating	kWh/(m ² yr)	13.4	9.4	9.4	17.6
	DHW	kWh/(m ² yr)	16	16	16	16
	Cooling	kWh/(m ² yr)				
	(Lighting*)	kWh/(m ² yr)	2.1	2.1	2.1	2.1
	Total	kWh/(m²yr)	31.5	27.5	27.5	35.7
Final energy ⁴¹	Heating (incl. aux. energy)	kWh/(m ² yr)	15	10.5	9.9	19.2
	DHW (incl. aux. energy)	kWh/(m ² yr)	17.6	17	17.4	17
	Cooling (incl. aux. energy)	kWh/(m ² yr)				
	Ventilation (Lighting*)	kWh/(m ² yr)	4.3	4.3	4.3	2.6
	(Household electricity*)	kWh/(m ² yr)	2.1	2.1	2.1	2.1
Total EPBD	kWh/(m²yr)	40.8	35	35.6	43	
Total	kWh/(m²yr)					

⁴⁰ **Net Energy** consumption is energy delivered inside the building, without distribution losses and without PEF.

⁴¹ **Final energy** consumption is the total energy consumed by end users. Thus, the energy that reaches the final consumer's energy meter and excludes energy used by the energy sector itself, i.e. without PEF.

Characteristic values		SI - SS1	SI - SS2	SI - SS3	SI - SS4
Primary energy ⁴²	District heating		38.8		
	Gas	25.5		10.9	
	Electricity (EPBD)	18.8	21.1	39.9	3.4
	Electricity (other)				
	Total EPBD ⁴³	44.3	59.9	39.9	43.1
Energy costs	Total (incl. other energy uses)				
	District heating		2.15		
	Gas	2.06		0.5	
	Electricity (EPBD) ⁵	1.13	1.27	2.39	1.93
	Electricity (other)				
Total EPBD ⁵	3.19	3.42	2.39	2.43	1.1
Investment costs	Total (incl. other energy uses)				
	Building envelope components	581	581	596	596
	Service systems	181	116	134	148
	Total	762	697	730	744
	Building envelope components (calculated average)	1	1	1	1
Maintenance costs	Building envelope components (calculated average)	8 634	8 634	8 857	8 857
	Service systems				
	% of investment costs	2.5	2.5	3	3.5
	€ / yr	6 724	4 309	5 974	7 696
	Total	15 358	12 943	14 830	16 554
					13 796

* not part of the building energy performance calculation in any of the 4 countries, but used to calculate the possible energy cost savings due to PV

⁴² **Primary Energy** Factors describes the efficiency of converting energy from primary sources (like fossil fuels...) to secondary energy carriers (e.g. electricity) that provides the services delivered to the end user to heat, cool, ventilate etc. the building (EN ISO 52000-1).

⁴³ Final energy demand included in the national EPBD calculations.



Specific coefficient of transmission thermal losses [W/m^2K] – is the ratio between the coefficient of transmission thermal losses (calculated according to SIST EN 13790) and the total external surface of the building.